

T27 HOLLOW FLANGE ROTARY TORQUE TRANSDUCER (U.S. & METRIC)

FEATURES & BENEFITS

- Capacities from 50 to 10K Nm (443 to 88.5K lbf-in)
- $\pm 5V$ output
- Very short axial length
- Large thru-hole design
- Bearingless

SPECIFICATIONS

ACCURACY – (MAX ERROR)		
Combined Error – %FS		± 0.1
Nonrepeatability – %RO		± 0.02
TEMPERATURE		
Effect on Zero – %RO / deg	$^{\circ}C$	± 0.02
Effect on Output – % / deg	$^{\circ}C$	± 0.01
Compensated Range	$^{\circ}C$	+5 to +45
	$^{\circ}F$	+41 to +113
Operating Range	$^{\circ}C$	0 to +60
	$^{\circ}F$	+32 to +140
ELECTRICAL		
Output – VDC		± 5
Bandwidth – kHz – dB		1 – 3
Supply Voltage – VDC		12 - 28
Supply Current – mA		90
Electrical Connection		12-pin binder
Resolution		Analog
MECHANICAL		
Safe Overload – %RO		200
Balance Grade – DIN ISO 1940		6.3
IP Rating		IP54
Material		Alloy steel

OPTIONS

- $\pm 10V$ output
- Speed measurement – 30 pulse, +5V TTL

STANDARD CONFIGURATION

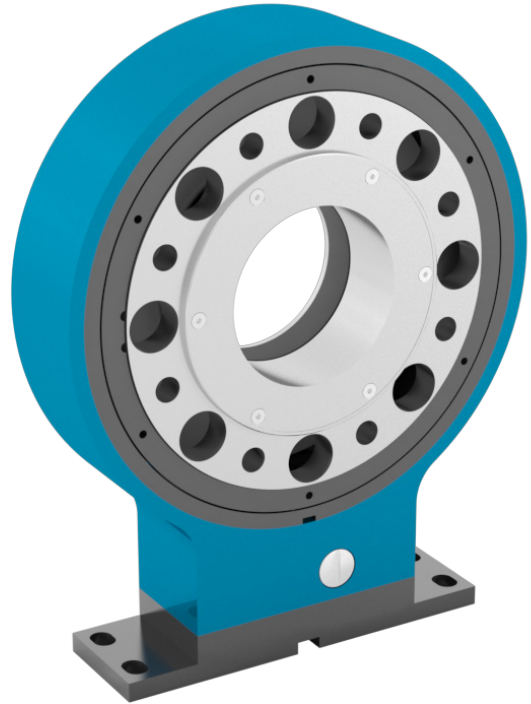

Model T27 (Shown)

PERFORMANCE PARAMETERS

CAPACITY		MAX RPM	SPRING RATE	MOMENT OF INERTIA ($kg \cdot m^2$)		MAX THRUST LOAD**		MAX SHEAR FORCE**	
(Nm)	(lbf-in)			(NM/rad)	Drive Side	Test Side	(N)	(lbf)	(N)
50	443	15,000	8.3×10^4	5.8×10^{-4}	1.1×10^{-3}	650	146	190	42.7
100	885	15,000	1.4×10^5	5.8×10^{-4}	1.1×10^{-3}	1.1K	247	330	74.2
200	1.77K	15,000	3.2×10^5	9.2×10^{-4}	1.8×10^{-3}	1.6K	360	550	124
500	4.43K	12,000	1.1×10^6	1.3×10^{-4}	4.0×10^{-3}	2K	450	1200	270
1K	8.85K	12,000	3.5×10^6	1.3×10^{-4}	4.1×10^{-3}	4K	899	2700	607
2K	17.7K	10,000	6.7×10^6	3.1×10^{-3}	1.3×10^{-2}	5.4K	1.21K	3300	742
5K	44.3K	8,000	14.3×10^6	7.8×10^{-3}	3.0×10^{-2}	5.7K	1.28K	5200	1.17K
10K	8.85K	8,000	14.3×10^6	7.8×10^{-3}	3.0×10^{-2}	5.7K	1.28K	5200	1.17K

U.S. dimensions and capacities are provided for conversion only. Standard products have International System of Units (SI) capacities and dimensions.

T27 HOLLOW FLANGE ROTARY TORQUE TRANSDUCER (U.S. & METRIC)

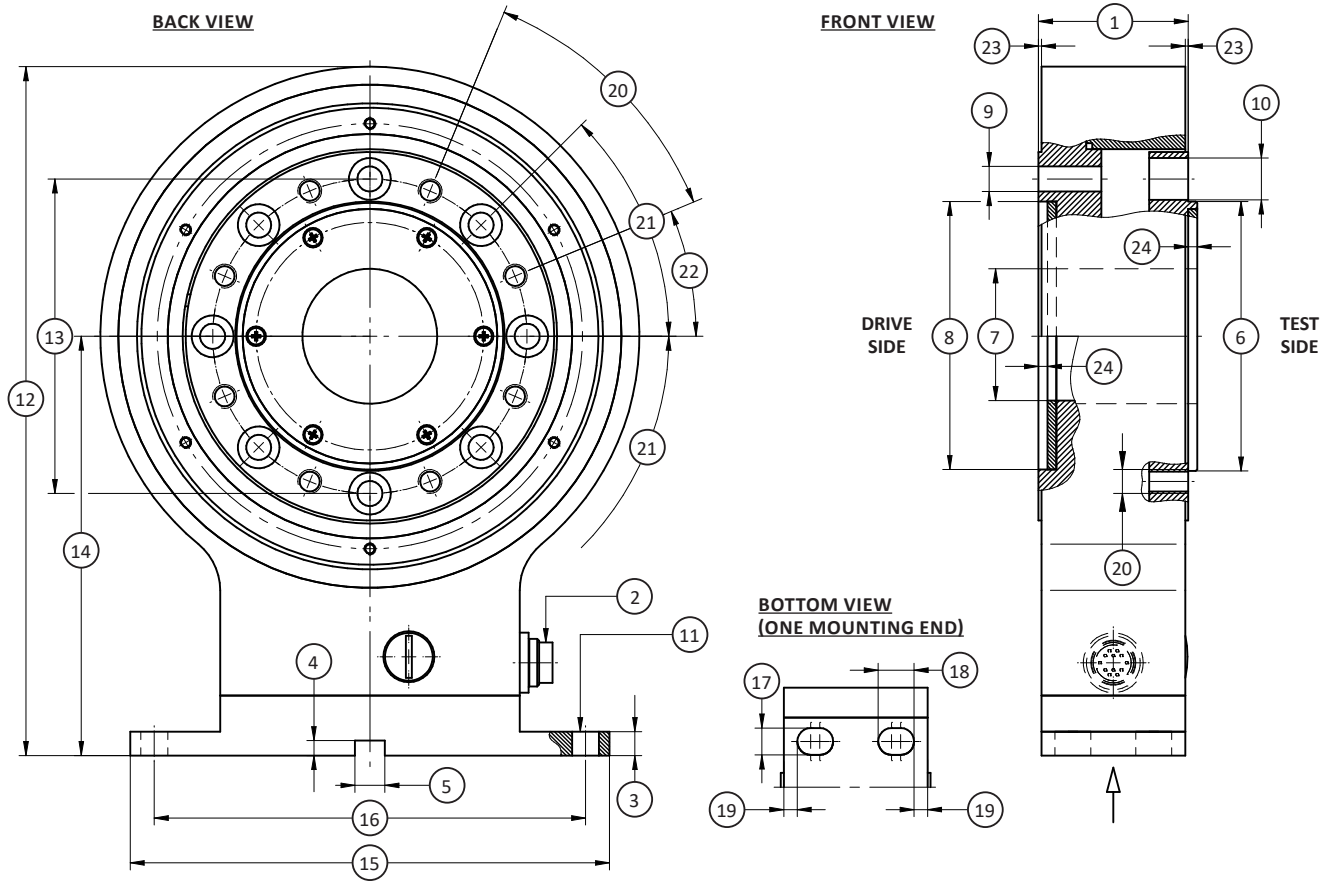

DIMENSIONS

See Drawing	CAPACITIES									
	Metric (Nm)	U.S. (lbf-in)	Metric (Nm)	U.S. (lbf-in)	Metric (Nm)	U.S. (lbf-in)	Metric (Nm)	U.S. (lbf-in)	Metric (Nm)	U.S. (lbf-in)
	50, 100	443, 885	200	1.77K	500, 1K	4.43K, 8.85K	2K	17.7K	5K, 10K	44.3K, 88.5K
mm	in	mm	in	mm	in	mm	in	mm	in	
(1)	50	2.0	50	2.0	50	2.0	55	2.2	55	2.2
(2)	Connector 12-pin		Connector 12-pin		Connector 12-pin		Connector 12-pin		Connector 12-pin	
(3)	8	0.3	8	0.3	8	0.3	8	0.3	8	0.3
(4)	5	0.2	5	0.2	5	0.2	5	0.2	5	0.2
(5)	∅10 ^{+0.1}	∅0.4 ^{+0.004}	∅10 ^{+0.1}	∅0.4 ^{+0.004}	∅10 ^{+0.1}	∅0.4 ^{+0.004}	∅10 ^{+0.1}	∅0.4 ^{+0.004}	∅10 ^{+0.1}	∅0.4 ^{+0.004}
(6)	∅75 g6	∅(2.9524 / 2.9516)	∅90 g6	∅(3.5428 / 3.5420)	∅110 g6	∅(4.3302 / 4.3294)	∅140 g6	∅(5.5112 / 5.5103)	∅174 g6	∅(6.8498 / 6.8488)
(7)	∅40 ^{+0.2}	∅1.6 ^{+0.008}	∅45 ^{+0.2}	∅1.6 ^{+0.008}	∅70 ^{+0.2}	∅2.8 ^{+0.008}	∅80 ^{+0.2}	∅3.1 ^{+0.008}	∅100 ^{+0.2}	∅3.9 ^{+0.008}
(8)	∅75 H7	∅2.9539 / 2.9527	∅90 H7	∅3.5447 / 3.5433	∅110 H7	∅4.3321 / 4.3307	∅140 H7	∅5.5134 / 5.5112	∅174 H7	∅6.8519 / 6.8504
(9)	∅6.4	∅0.25	∅8.4	∅0.33	∅13	∅0.5	∅15	∅0.6	∅19	∅0.7
(10)	∅11	∅0.4	∅14	∅0.6	∅20	∅0.8	∅24	∅0.9	∅30	∅1.2
(11)	M8 x 4		M8 x 4		M8 x 4		M8 x 4		M8 x 4	
(12)	211	8.3	230	9.1	250	9.8	300	11.8	360	14.2
(13)	∅87 ^{±0.1}	∅3.4 ^{+0.004}	∅105 ^{±0.1}	∅4.1 ^{±0.004}	∅133 ^{±0.1}	∅5.2 ^{±0.004}	∅165 ^{±0.1}	∅6.5 ^{±0.004}	∅206 ^{±0.1}	∅8.1 ^{±0.004}
(14)	130.5 ^{±0.1}	5.14 ^{+0.004}	140 ^{±0.1}	5.5 ^{±0.004}	150 ^{±0.1}	5.9 ^{±0.004}	175 ^{±0.1}	6.9 ^{±0.004}	205 ^{±0.1}	8.1 ^{±0.004}
(15)	160	6.3	160	6.3	160	6.3	160	6.3	160	6.3

T27 v2.7 02-03-2021

T27 HOLLOW FLANGE ROTARY TORQUE TRANSDUCER (U.S. & METRIC)

DIMENSIONS (CONTINUED)

See Drawing	CAPACITIES									
	Metric (Nm)	U.S. (lbf-in)	Metric (Nm)	U.S. (lbf-in)	Metric (Nm)	U.S. (lbf-in)	Metric (Nm)	U.S. (lbf-in)	Metric (Nm)	U.S. (lbf-in)
	50, 100	443, 885	200	1.77K	500, 1K	4.43K, 8.85K	2K	17.7K	5K, 10K	44.3K, 88.5K
	mm	in	mm	in	mm	in	mm	in	mm	in
(16)	144 ^{±0.1}	5.7 ^{±0.004}	144 ^{±0.1}	5.7 ^{±0.004}	144 ^{±0.1}	5.7 ^{±0.004}	144 ^{±0.1}	5.7 ^{±0.004}	144 ^{±0.1}	5.7 ^{±0.004}
(17)	9	0.4	9	0.4	9	0.4	9	0.4	9	0.4
(18)	12	0.5	12	0.5	12	0.5	12	0.5	12	0.5
(19)	4.5	0.18	4.5	0.18	4.5	0.18	4.5	0.18	4.5	0.18
(20)	8 x 45° (=360°)		8 x 45° (=360°)		8 x 45° (=360°)		8 x 45° (=360°)		8 x 45° (=360°)	
(21)	45°		45°		45°		45°		45°	
(22)	22.5°		22.5°		22.5°		22.5°		22.5°	
(23)	1	0.04	1	0.04	1	0.04	3.5	0.14	3.5	0.14
(24)	3	0.1	3	0.1	3	0.1	3	0.1	3	0.1