

ORT 230/240 series Optical Torque Transducer



Digital ORT 230/240 series Optical Torque Transducer

The ORT 230/240 Transducer offers an ideal means for precise dynamic measurement of rotary and static torque less than 100Nm and for bandwidths of up to 50KHz.

The new TorqSense ORT 230/240 torque sensors replace the E200 ORT series and feature all new electronics that have produced significant performance gains in resolution, frequency response, reduced sensor current consumption and faster digital data throughput.

Benefits

- Low inertia – High Speed capability because electronics are not fixed onto shaft
- Non contact/brushless measurement
- High Bandwidth
- 200% safe mechanical overload
- Excellent noise immunity
- Separate electronics module
- Operates both statically and dynamically - clockwise/anti-clockwise
- Any full scale torque can be specified within standard range: 10mNm through to 100Nm
- Lifetime warranty



TorqSense ORT 230 series transducers offer:

- Fixed voltage or current analog outputs (one for torque and the other for speed or power) for interfacing with analog instrumentation
- BIT Self-diagnostics for letting the manufacturer know that the transducer's torque, speed ratings and calibration due date have not been exceeded.
- Simple 'Sensor status' output pin
- Sensors to monitor shaft temperature for better compensation and accuracy

Whereas, TorqSense ORT 240 series transducers offer:

- Digital outputs, such as RS232, CANbus and USB, for interfacing with modern instrumentation and laptops
- Digital input for configuring transducer via PC
- 2 x user selectable voltage or current analog outputs (one for torque and the other for speed, power or peak torque) for interfacing with analog instrumentation
- Transducer configuration software to allow user to changes transducer variables
- BIT Self-diagnostics for letting users know data is trustworthy, that the transducer's torque, speed ratings and calibration due date have not been exceeded
- Simple 'Sensor status' output pin
- Sensors to monitor shaft temperature for better compensation and accuracy
- Ability to connect up to 10 transducers using USB

Technology

An extensively developed measurement principle is used, in which the intensity of light beams is measured by means of photovoltaic detectors, and the electrical output is used to provide precise indication of the applied torque transmitted by the shaft.

The use of this technique results in a transducer being able to sense torque bi-directionally, have a fast mechanical and electrical response, low inertia, and complete freedom from brushes or complex electronics. The absence of brush gear allows high-speed operation with a continuous rating of up to 30,000 RPM standard. Further increases in RPM are available as an option depending upon shaft size.

The torque shaft is of low compliance maximum torsion deflection at full-scale deflection. The lamps providing the light source are selected to ensure long life and high stability with the light intensity automatically controlled within the transducer body by a monitor cell.

TORQVIEW Software

TorqView is an easy to use advanced torque monitoring software, available to assist data recording and instrumentation displays that interface with Windows based PCs. Features include: 3 types of display, text files compatible with Matlab and Excel and Real time chart plotting.

See TorqView datasheet TSE2099R for more details.



LabView VIs are available for users to design their own process control applications. DLLs are also available for users to write their own custom software.

Standard Specifications

| Model | Torque Range * | | Maximum Speed (RPM) | Shaft Type |
|--------------|-----------------------------|------------------------------|------------------------|------------|
| | Minimum | Maximum | | |
| ORT230/240-C | 0 to 10mNm (0 to 1ozf.in) | 0 to 20mNm (0 to 3ozf.in) | 30000 | Plain |
| ORT230/240-D | 0 to 25mNm (0 to 3.5ozf.in) | 0 to 100mNm (0 to 10ozf.in) | 30000 | Plain |
| ORT230/240-E | 0 to 150mNm (0 to 15ozf.in) | 0 to 750mNm (0 to 100ozf.in) | 30000 | Plain |
| ORT230/240-F | 0 to 800mNm (0 to 7lbf.in) | 0 to 1Nm (0 to 10lbf.in) | 30000 | Flat |
| ORT230/240-G | 0 to 1.5Nm (0 to 15lbf.in) | 0 to 20Nm (0 to 200lbf.in) | 20000 | Keyways |
| ORT230/240-H | 0 to 25Nm (0 to 250lbf.in) | 0 to 100Nm (0 to 1000lbf.in) | 15000 | Keyways |

* Calibration is possible in any equivalent SI, FPS or MKS units, e.g. gf.cm, lbf.ft, cNm
Transducers may be specified to any torque range between the maximum and minimum for each model.
For example ORT241-C 15mNm, or ORT231-G 10Nm.

Dimensions. Shaft C, D, E, F (10mNm to 1Nm)

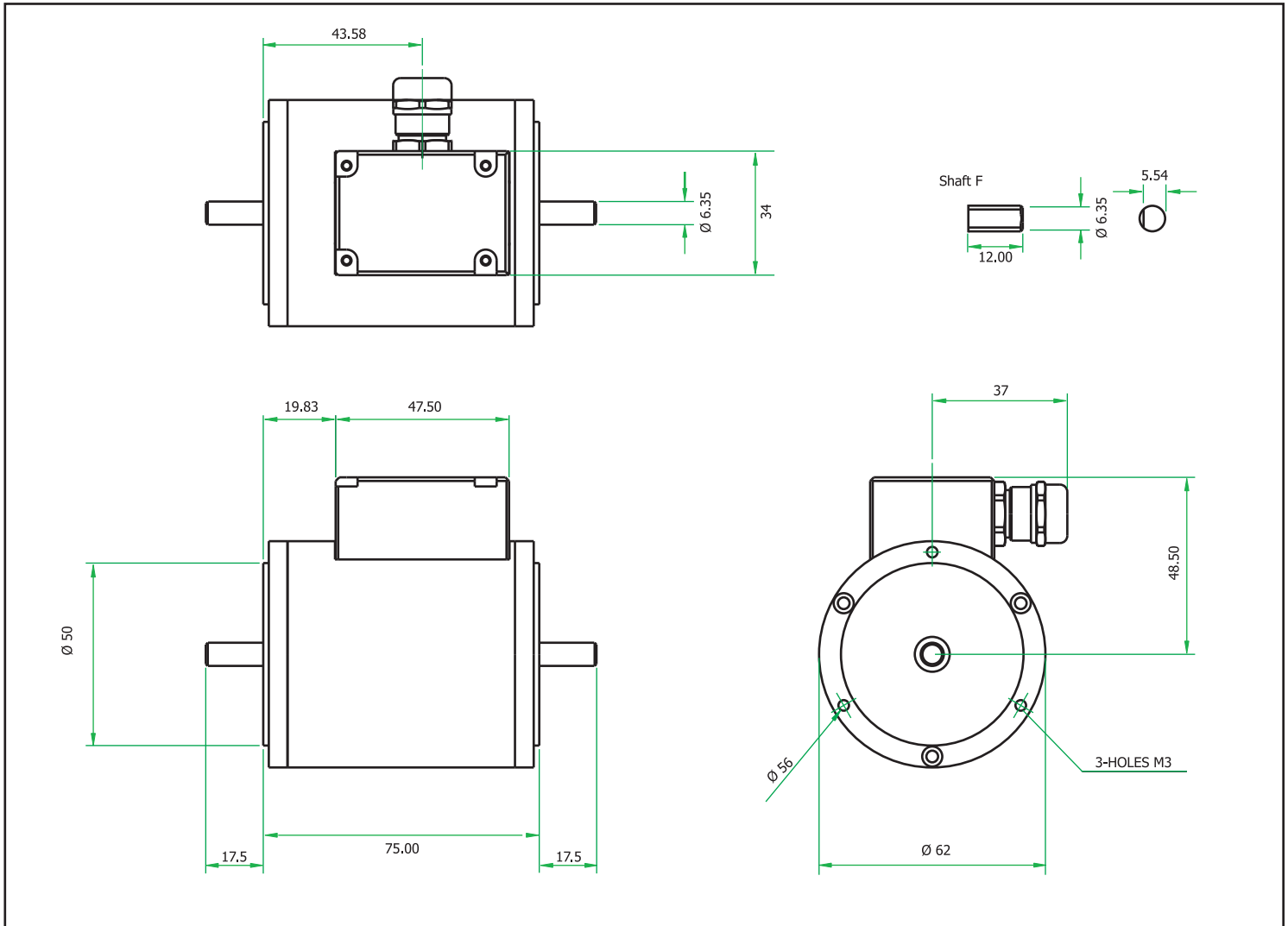

| Parameter | Data | | | | Units |
|------------------------------|-----------------------|-------------------|--------------------|----------------|-------|
| Mechanical Properties | | | | | |
| Torque (Max) | 20mNm (3ozf.in) | 100mNm (10ozf.in) | 750mNm (100ozf.in) | 1Nm (10lbf.in) | |
| Shaft code | C | D | E | F | |
| Speed (Max) | 30000 | 30000 | 30000 | 30000 | RPM |
| Shaft type | Plain | Plain | Plain | Flat | |
| Max measurable load limit | 120 (of rated torque) | | | | % |
| Static safe load breaking | 200 (of rated torque) | | | | % |
| Transducer weight, approx | 425 | 425 | 425 | 425 | grams |

Data parameters measured at 20°C
Sensor Technology Ltd reserves the right to change specification and dimensions without notice.

Shaft G (1.5Nm to 20Nm)

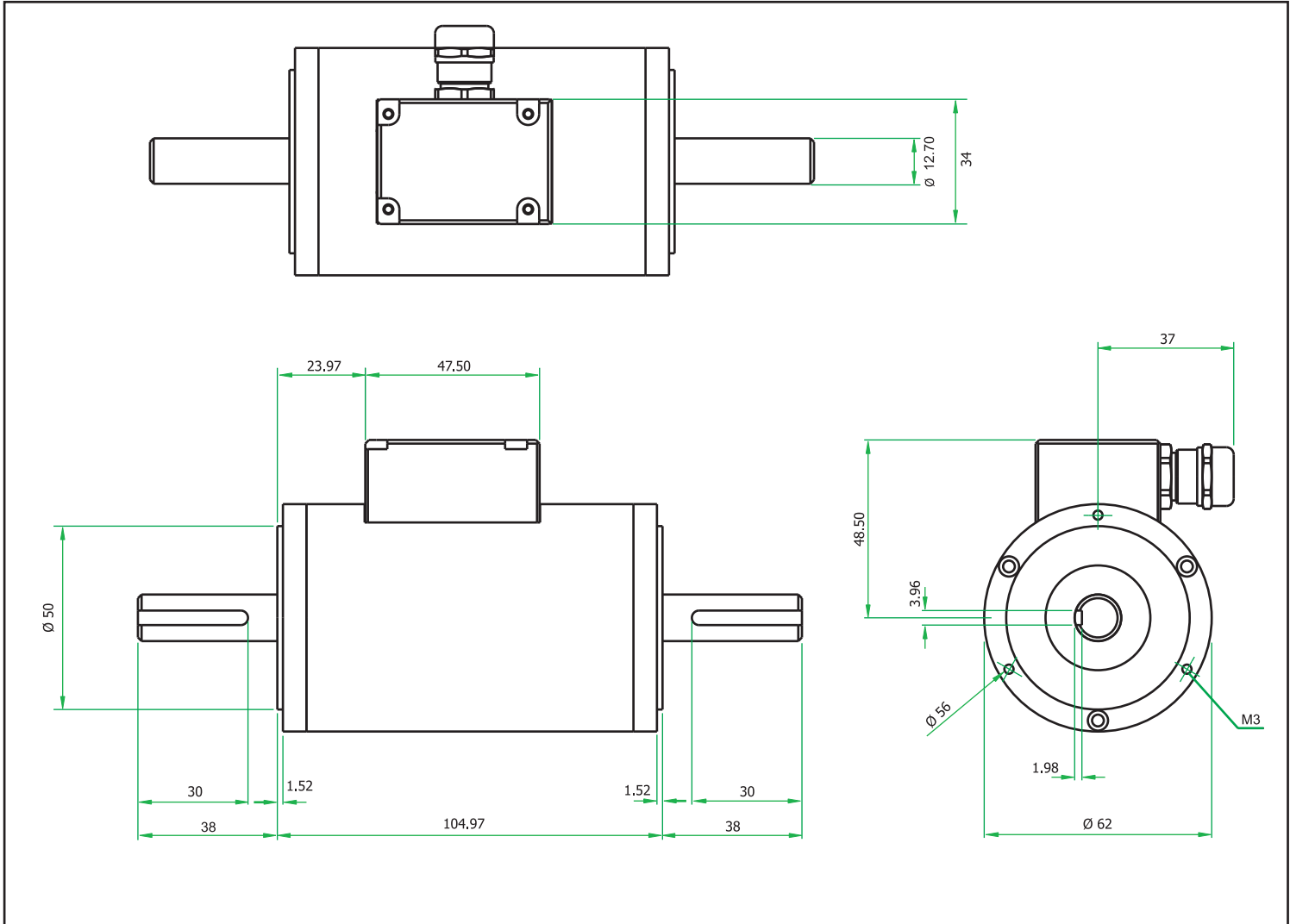

| Parameter | Data | Units |
|------------------------------|-----------------------|-------|
| Mechanical Properties | | |
| Torque (Max) | 20Nm (200lbf.in) | |
| Shaft code | G | |
| Speed (Max) | 20000 | RPM |
| Shaft type | Keyways | |
| Max measurable load limit | 120 (of rated torque) | % |
| Static safe load breaking | 200 (of rated torque) | % |
| Transducer weight, approx | TBC | grams |

Data parameters measured at 20°C
 Sensor Technology Ltd reserves the right to change specification and dimensions without notice.

Shaft H (25Nm to 100Nm)

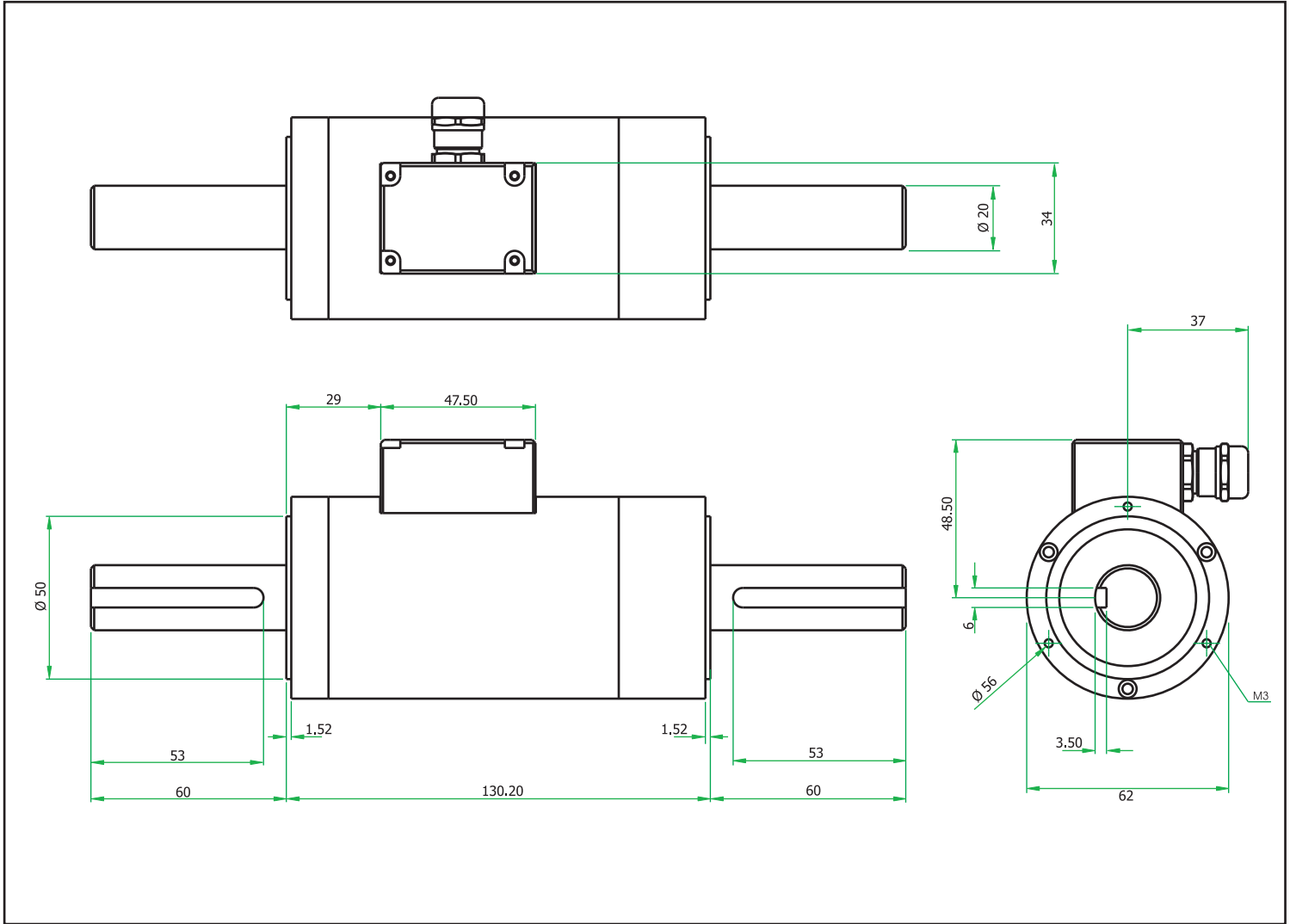

| Parameter | Data | Units |
|------------------------------|-----------------------|-------|
| Mechanical Properties | | |
| Torque (Max) | 100Nm (1000lbf.in) | |
| Shaft code | H | |
| Speed (Max) | 15000 | RPM |
| Shaft type | Keyways | |
| Max measurable load limit | 120 (of rated torque) | % |
| Static safe load breaking | 200 (of rated torque) | % |
| Transducer weight, approx | TBC | grams |

Data parameters measured at 20°C
 Sensor Technology Ltd reserves the right to change specification and dimensions without notice.

ORT 230/240 Series Electronics Module

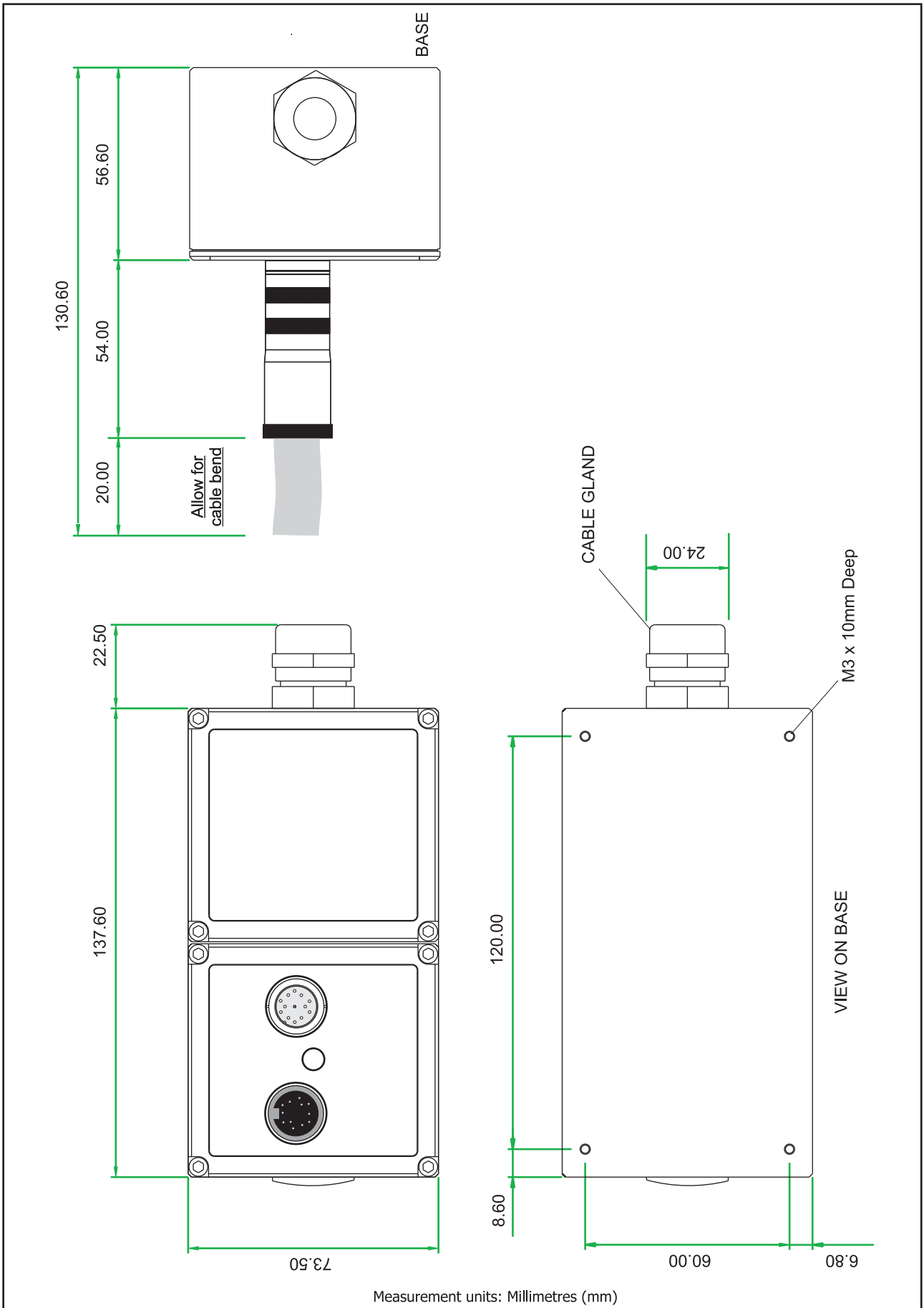

Data parameters measured at 20°C
 Sensor Technology Ltd reserves the right to change specification and dimensions without notice.

ORT 230/240 Series Torque Transducers - Data Specification

| Parameter | Condition | Data | Units | | | | | | |
|---|---|--|--|--|-------|------|------|------|-----|
| Rotation speed/angle of rotation measurement system | | | | | | | | | |
| Measurement method | Opto switch through slotted disc | | | | | | | | |
| Direct output signal | Pulse output direct from opto switch (TTL, 5V square wave), output is independent of any analog or digital processing. | | | | | | | | |
| Digital Processing Techniques Processing modes run simultaneously and can be applied to either analog channel or accessed individually via a digital connection. | Processing Method | Update rate for analog and digital outputs | | | | | | | |
| | Mode 1 (Slow Method) Frequency Count | 1 | | | | | | | |
| | Mode 2 (Fast Method) Period Count | 0 RPM | 1 | | | | | | |
| | | < 2000 RPM | RPM | | | | | | |
| > 2000 RPM | RPM x (1 / (⌊ (RPM - 1) / 2000 ⌋ + 1)) | | | | | | | | |
| Rotational speed (max) | (See Note 1) | 30,000 | 20,000 | 15,000 | RPM | | | | |
| Temperature | | | | | | | | | |
| Measurement method | IR temperature sensor monitoring actual shaft temperature | | | | | | | | |
| Temperature accuracy | ±1 | | | °C | | | | | |
| Reference temperature, T _{RT} | 20 | | | °C | | | | | |
| Operating range, ΔT _O | -10 to +50 | | | °C | | | | | |
| Storage range, ΔT _S | -20 to +70 | | | °C | | | | | |
| Temperature drift (FS) | Max | 0.05 | | %FS/°C | | | | | |
| Specifications | | | | | | | | | |
| Combined non-linearity and hysteresis | ±0.5 | | | %FS | | | | | |
| Resolution | 0.02 | | | %FS | | | | | |
| Repeatability | 0.1 | | | %FS | | | | | |
| ORT 230 Series Transducers ONLY | | | | | | | | | |
| Accuracy | 20°C, SM (See Note 2) | Usb ±0.5 | | %FS | | | | | |
| 3dB Bandwidth | (See Notes 3&4) | 25,000 | | Hz | | | | | |
| ORT 240 Series Transducers ONLY | | | | | | | | | |
| Digital averaging | (See Note 3) | 2 | 4 | 8 | 16 | 32 | 64 | 128 | N |
| Accuracy | 20°C, SM (See Note 2) | ±0.5 | ±0.5 | ±0.5 | ±0.5 | ±0.5 | ±0.5 | ±0.5 | %FS |
| 3dB Bandwidth | (See Note 4) | 12,500 | 6,250 | 3,125 | 1,562 | 781 | 390 | 195 | Hz |
| Analog output | | | | | | | | | |
| Output voltages (Torque/Speed/Power) | Options available: ±1 / ±5 / ±10 / Unipolar (ORT230 Series default setting is ±5Vdc) (ORT240 Series output voltages are user selectable) | | | Vdc | | | | | |
| Load impedance | Maximum 1 | | | KΩ | | | | | |
| Output currents (Torque/Speed/Power) | Options available: 4-20 / 0-20 / 12±8 (ORT240 Series output currents are user selectable) | | | mA | | | | | |
| 4-20mA Loop resistance | Should not exceed 400 | | | Ω | | | | | |
| Digital output (ORT240 Series Transducers ONLY) | | | | | | | | | |
| Connections | CAN Bus | | RS232 | USB | | | | | |
| Configuration | CAN 2.0B, 11bit Message Identifiers | | Data Bits: 8, Parity: None, Stop Bits: 1 | USB 2.0 Full-Speed | | | | | |
| Baud Rate(s) | 1 Mbps, 500 Kbps, 250 Kbps, 100 Kbps | | 115200 bps, 38400 bps, 9600 bps | 12 Mbps | | | | | |
| Output Rate (Note 5) | Up to 10 KHz | | Up to 1.1 KHz | Single Transfer Up to 500 Hz Bulk Transfer Up to 10 KHz | | | | | |
| Power supply | | | | | | | | | |
| Nominal voltage, V _s | 12 to 32 (max) | | | V | | | | | |
| Current consumption, I _s | 230 (max) @ 12 VDC | | | mA | | | | | |
| Power consumption, W _s | 3 | | | W | | | | | |
| Allowed residual ripple of supply voltage, V _{ripple} | 500 (above nominal supply voltage) | | | mVp-p | | | | | |
| Electromagnetic compatibility | | | | | | | | | |
| EMC compatibility | EN 61326:2006 | | | | | | | | |

Note 1: Please consult factory for applications requiring rotational speeds that exceed maximum figures given. Transducers fitted for IP65 will have running speeds considerably reduced, increased drag torque and accuracy can be affected.

Note 2: SM – Static Mode. Dynamic values will depend upon user application and has to be adjusted accordingly.

Note 3: Digital averaging can be configured by user to optimise accuracy/frequency response for specific user applications. Digital averaging default setting is N=16. For details see User Manual.

Note 4: >5Khz Sample Rate. Up to 10KHz sample rate possible, please consult factory. Digital averaging also affects the analog output, max analog output 3dB Bandwidth = 5Khz when digital average is 1.

Note 5: Output rate figures are calculated from the time taken to capture 10000 torque readings. Testing was conducted with each connection method configured at its maximum baud rate. The maximum output rate available for CAN and USB is dependant on the transducers setup. USB - USB is a host based bus architecture, because of this the output rate achievable will be affected by other bus traffic and host activity. USB has two transfer modes, Single Transfer which requests 1 reading at a time and Bulk Transfer which transfers readings in blocks of 50 Torque/Speed pairs. CAN Bus - to achieve a Torque reading output rate of 10KHz, the Speed reading output rate must be reduced to 100Hz.

Data parameters measured at +20°C

Sensor Technology Ltd reserves the right to change specification and dimensions without notice.

ORT 230/240 Series Torque Transducers - Standard Range

● – Standard feature ◇ – Optional feature

| | ORT 230/240 Series | | Option Code | Remarks |
|---|--------------------|---------|-------------|---|
| | ORT 230 | ORT 240 | | |
| Torque, Speed, Power Outputs | ORT 230 | ORT 240 | | |
| Torque only | 230 | 240 | | |
| Torque & Speed (60 pulses/rev) | 231 | | | User to specify RPM/FSD when ordering |
| Torque & Power (60 pulses/rev) | 233 | | | User to specify Power/FSD when ordering |
| Torque & Speed (60 pulses/rev) or Power | | 241 | | Outputs are user selectable |
| Standard features | | | | |
| Voltage output $\pm 5v$ FSD (Fixed) | ● | | B | |
| Voltage outputs from $\pm 1v$ to $\pm 10v$ FSD and unipolar (Variable) | | ● | | Output is user selectable |
| USB2.0 full speed 12 Mbps Digital output | | ● | | |
| RS232 output | | ● | | |
| Torque Averaging & Torque Peak | | ● | | |
| Self Diagnostics | ● | ● | | |
| Internal temperature measurement | ● | ● | | Value available on ORT240 series only |
| Deep grooved shielded bearings with oil lubrication | ● | ● | | |
| Ingress Protection (IP) 54 | ● | ● | | |
| Link Cable (1.5m) | ● | ● | | From sensor head to electronics module |
| Optional features | | | | |
| Keyed Shaft Ends | ● | ● | K | 1Nm flats, below 1Nm plain |
| Plain Shaft Ends | ◇ | ◇ | P | Shaft length may be longer than keyed end shafts – consult factory for length. All sensors below 1Nm will be plain. |
| Splined Shaft Ends | ◇ | ◇ | T | Consult factory for details |
| Voltage output $\pm 1v$ FSD (Fixed) | ◇ | | A | In place of Option B |
| Voltage output $\pm 10v$ FSD (Fixed) | ◇ | | C | In place of Option B |
| Customer Specified Voltage Output (Fixed) | ◇ | | U | In place of Option B. User to specify range/scale when ordering |
| Current output 0-20mA (Fixed) | ◇ | | D | In place of Voltage output options |
| Current output 4-20mA (Fixed) | ◇ | | E | In place of Voltage output options |
| Current output 12 \pm 8mA (Fixed) | ◇ | | V | In place of Voltage output options |
| Current output 0-20mA, 4-20mA & 12 \pm 8mA (Variable) | | ◇ | F | Current output is user selectable and in place of Voltage output. However user can reselect a Voltage output, if required. (Note 6) |
| CANbus output | | ◇ | H | In place of RS232 |
| High Speed Bearings (See Note 7 below) | ◇ | ◇ | J | Consult factory for maximum speed allowance |
| Sealed Bearings | ◇ | ◇ | S | |
| Ingress Protection (IP) 65 –for sensor and electronics (See Note 8 below) | ◇ | ◇ | L | |
| Link Cable (>1.5m) | ◇ | ◇ | R | Consult factory for length |

Note 6: 2 x analog channels available. Default settings are Channel 1 (voltage/current) – torque. Channel 2 (voltage/current) – speed or power, if ordered.

Note 7: At very high speeds, for better balance the factory recommend plain or splined shafts.

Note 8: Transducers fitted for IP65 will have running speeds considerably reduced, increased drag torque and accuracy can be affected.

Data parameters measured at +20°C
Sensor Technology Ltd reserves the right to change specification and dimensions without notice.

ORT 230/240 Series Torque Transducers – Connector and Lead Options

| Connectors & Leads | ORT 230/240 Series | | Option Code | Remarks/Purpose |
|---|--------------------|---------|-------------|--|
| | ORT 230 | ORT 240 | | |
| Analog Connector <i>12 Pin Lumberg (female)</i> | ◇ | ◇ | ACC 1 | <i>For user to self wire</i> |
| Digital Connector <i>12 Pin Lumberg (male)</i> | | ◇ | ACC 2 | <i>For user to self wire</i> |
| Analog Lead (Length 2.5m) <i>12 Pin Lumberg (female) to 15 way 'D' type connector (female)</i> | ◇ | ◇ | ACC 3 | <i>For connecting ORT to user's system via 15 pin 'D' connector</i> |
| Digital Lead (Length 2.5m) <i>12 Pin Lumberg (male) to 15 way 'D' type connector (male)</i> | | ◇ | ACC 4 | <i>For connecting ORT to user's system via 15 pin 'D' connector</i> |
| Digital Lead Adapter (Length 1m) <i>15 Way 'D' type (female) to RS232 and Power Connectors</i> | | ◇ | ACC 5 | <i>For connecting ORT to PC via RS232 [Also needs Digital Lead (ACC4) to connect to ORT]</i> |
| Digital Lead Adapter (Length 1m) <i>15 Way 'D' type (female) to RS232, USB and Power Connectors</i> | | ◇ | ACC 6 | <i>For connecting ORT to PC via USB or RS232 [Also needs Digital Lead (ACC4) to connect to ORT]</i> |
| Digital Lead Adapter (Length 1m) <i>15 Way 'D' type (female) to CANbus and Power Connectors</i> | | ◇ | ACC 8 | <i>For connecting ORT to PC via CANbus (Option H) [Also needs Digital Lead (ACC4) to connect to ORT]</i> |
| Digital Lead Adapter (Length 1m) <i>15 Way 'D' type (female) to CANbus, USB and Power Connectors</i> | | ◇ | ACC 9 | <i>For connecting ORT to PC via USB (Option G) or CANbus (Option H) [Also needs Digital Lead (ACC4) to connect to ORT]</i> |

ORT 230/240 Series Torque Transducers – Additional related products

| | Code | Remarks/Purpose |
|---------------------------------|-------|-----------------------------------|
| Transducer Display ETD | ETD | <i>Display readout</i> |
| AC Mains Adapter Power Supply | PSU 1 | <i>For providing 12-32Vdc</i> |
| Transducer Signal Breakout Unit | SBU 2 | |
| TorgView | TV | <i>Torque Monitoring Software</i> |

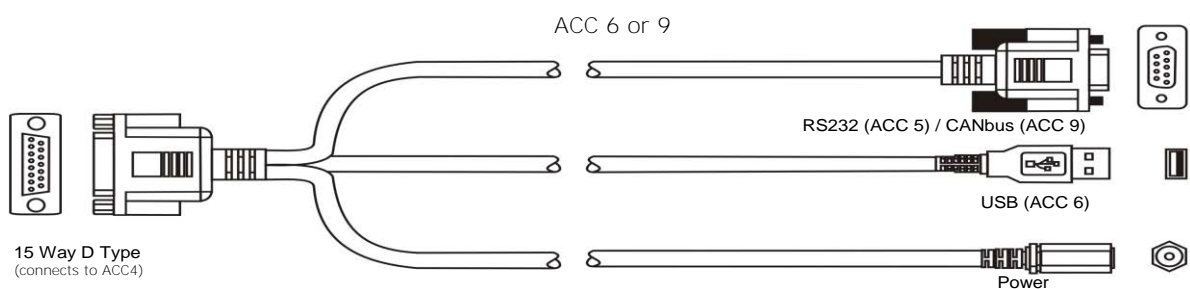
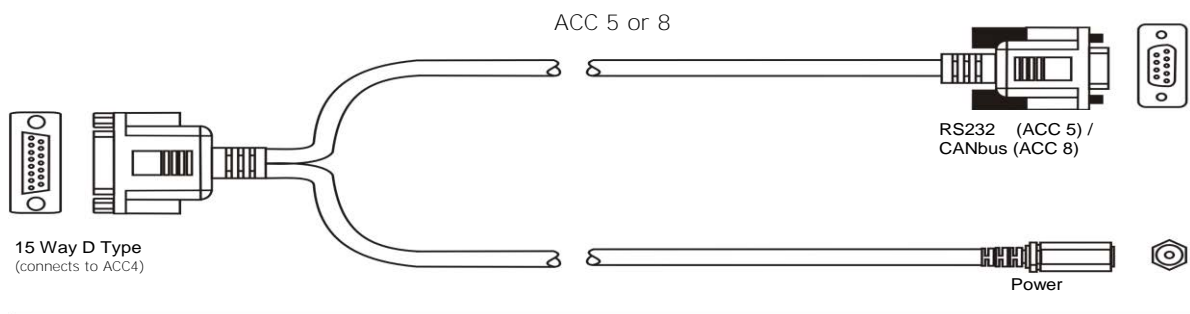
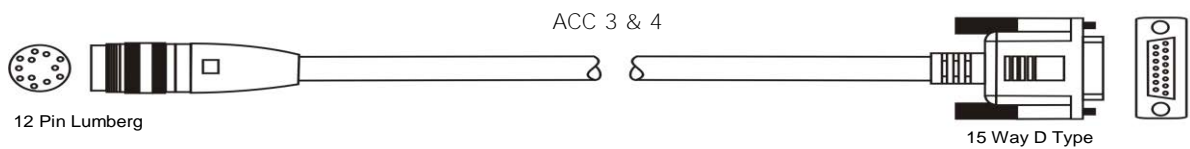

*Data parameters measured at +20°C
Sensor Technology Ltd reserves the right to change specification and dimensions without notice.*

When you order a Torque Transducer please note that any torque/FSD is possible between ranges – please specify rated torque and options using the following format:

| | | | |
|---|---------------------|---------------------------------|---|
| For example: <i>ORT</i> | <i>231 - 15Nm -</i> | <i>K-CL</i> | A 'basic' transducer with torque and speed outputs, rated and calibrated to 15Nm FSD with keyed ends, ±10v and IP65 protection. |
| Your transducer requirement: <i>ORT</i> | | | |
| Max speed (if applicable) | | RPM | |
| Connector & Lead options | | (if applicable) <i>See over</i> | |
| Additional related products | | (if applicable) <i>See over</i> | |

Glossary of terms and definitions used in this datasheet

- *Accuracy* - The degree of conformity of a measured or calculated quantity, which will show the same or similar results. Accuracy of the overall TorqSense system is limited by the combined error of several factors such as linearity, hysteresis, temperature drifts and other parameters affecting measurements. If errors in the system are known or can be estimated, an overall error or uncertainty of measurement can be calculated.
- *Digital averaging* – The application of algorithms to reduce white noise. In any electronic system, electronic white noise is mixed with the signal and this noise usually limits the accuracy. To reduce the influence of white noise and increase the accuracy of the system different averaging algorithms can be applied. In the TorqSense system a flying digital averaging technique is applied to reduce the white noise commensurate with the level of accuracy required. However, as any averaging algorithm works as a low pass filter, the more averaging that is applied the lower the frequency response. Therefore, each Torqsense system should be optimised to the customer's requirements by choosing the right combination of accuracy/frequency response. Please see relevant part of the Datasheet and User Manual.

Data parameters measured at +20°C

Sensor Technology Ltd reserves the right to change specification and dimensions without notice.