

Operation Manual for Torque Sensors

For below and similar Types



TS14



TS11



TS17



TS18



TS16



TS15



TS19

References in this Text

1.6 Warning Notes; Page 4



Attention must be paid to the accident prevention regulations of the trade associations. During operation the safety precautions must be serviceable.

4 Mechanical Assembly; Page 6



Caution: During the assembly inadmissibly large forces may not act on the sensor or the couplings. At small torques (< 20 N·m) connect the sensor electrically during the assembly and observe the signal, the measurement signal may not exceed the limit values.



During the assembly, the sensor must be supported to protect it from falling down.



Caution at permutation of drive side and measuring side.

4.1 Sensors up to 15 N·m; Page 6



Sensors with nominal torques up to 15 N·m are very sensitive regarding overload; therefore treat the sensors with great caution.

6.1 Engaging; Page 8



The warming-up period of the torque sensor is approx. 5 min.

6.4.2 Natural Resonance; Page 9



Operation of the device in natural resonance can lead to permanent damages.

Contents

1	Read First.....	4
1.1	Safety and Caution Symbols.....	4
1.2	Intended Use.....	4
1.3	Dangers.....	4
1.3.1	Neglecting of Safety Notes	4
1.3.2	Remaining Dangers	4
1.4	Reconstructions and Modifications	4
1.5	Personnel	4
1.6	Warning Notes	4
2	Term Definitions	5
2.1	Terms	5
2.2	Definition of the Pictograms on the Torque Sensor	5
3	Product Description	5
3.1	Mechanical Setup.....	5
3.2	Electrical Setup	5
4	Mechanical Assembly.....	6
4.1	Sensors up to 15 N·m	6
4.2	Flange Connection	6
4.3	Shaft Connection.....	6
4.4	Inside Square and Outside Square.....	6
5	Electrical Connection.....	7
5.1	Pin Connection.....	7
5.2	Free Cable Ends	7
5.3	Cable.....	7
5.4	Shielding Connection	7
5.5	Extension Cable	8
5.6	Running of Measuring Cables.....	8
6	Measuring.....	8
6.1	Engaging	8
6.2	Direction of Torque.....	8
6.3	Static / Quasi-Static Torques	8
6.4	Dynamic Torques.....	8
6.4.1	General	8
6.4.2	Natural Resonances	9
6.5	Disturbance Variables	9
6.6	Calibration Control (Option)	9
7	Maintenance.....	10
7.1	Maintenance Schedule	10
7.2	Trouble Shooting.....	10
8	Decommission.....	10
9	Transportation and Storage	10
9.1	Transportation	10
9.2	Storage.....	11
10	Disposal	11
11	Calibration.....	11
11.1	Proprietary Calibration.....	11
11.2	DKD-Calibration.....	11
11.3	Re-Calibration.....	11
12	Data Sheet.....	11

1 Read First

1.1 Safety and Caution Symbols



Caution:

Injury Risk for Persons
Damage of the Device is possible



Note:

Important points to be considered

1.2 Intended Use

Torque sensors are intended for the measurement of torque. This measurement is further suitable for control tasks. The valid safety regulations should be absolutely respected. The torque sensors are not safety components in the sense of the intended use. The sensors need to be transported and stored appropriately. The assembly, commissioning and disassembling must take place professionally.

1.3 Dangers

The torque sensor is fail-safe and corresponds to the state of technology.

1.3.1 Neglecting of Safety Notes

At inappropriate use, remaining dangers can emerge (e.g. by untrained personnel). The operation manual must be read and understood by each person entrusted with the assembly, maintenance, repair, operation and disassembly of the torque sensor.

1.3.2 Remaining Dangers

The plant designer, the supplier, as well as the operator must plan, realize and take responsibility for safety-related interests for the sensor. Remaining dangers must be minimized. Remaining dangers of the torque measurement technique must be pointed out.

1.4 Reconstructions and Modifications

Each modification of the sensors without our written approval excludes liability on our part.

1.5 Personnel

The installation, assembly, commissioning, operation and the disassembly must be carried out by qualified personnel only. The personnel must have the knowledge and make use of the legal regulations and safety instructions.

1.6 Warning Notes



Attention must be paid to the accident prevention regulations of the trade associations.
During operation the safety precautions must be serviceable.

2 Term Definitions

2.1 Terms

Measuring Side:

Shaft connection in which the torque to be measured is applied. Usually this side has the smallest moment of inertia.

Drive Side:

The shaft end on the opposite side of the measuring side with the larger moment of inertia. At static torque sensors the housing is fastened on this side.

Low Torque Resistance Side:

The shaft of the arrangement (drive, load) which can be turned considerably smaller with torque than the nominal torque of the torque sensor $M \ll M_{\text{nom}}$.

2.2 Definition of the Pictograms on the Torque Sensor

The measuring side of the torque sensor is designated as follows:

Measuring side:  or M

More information can be found on the data sheet if needed.

3 Product Description

The sensor measures static and dynamic torques. The mounting position of the torque sensor is horizontally or vertically.

Caution: it is to be differentiated between measuring side and drive side, see data sheet of the sensor: <http://www.interfaceforce.com>

3.1 Mechanical Setup

The sensors do not contain rotary parts.

They consist of a torsion body with different connection possibilities (flanges, shafts, square, hexagonal etc.). The torsion body, applied with strain gauges, is protected by a housing. A plug or a cable connection is fixed at the housing.

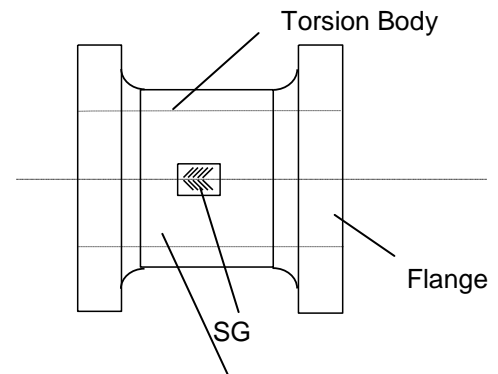

3.2 Electrical Setup

The strain gauge full bridge is directly connected at the plug or at the cable.

Optionally a calibration control can be integrated. For this, the SG full bridge gets detuned by an external switch in such a way, that at the output the measuring signal, which is corresponding to the positive nominal torque, can be measured.

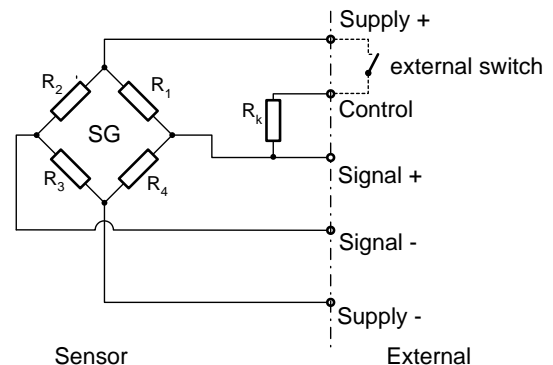

Basic sketch of the strain gauge full bridge with option calibration control

4 Mechanical Assembly



Caution: During the assembly inadmissibly large forces may not act on the sensor or the couplings. At small torques (< 20 N·m) connect the sensor electrically during the assembly and observe the signal, the measurement signal may not exceed the limit values



During the assembly the sensor must be supported to protect it from falling down.

It is to be differentiated between measuring side and drive side of the sensor. The housing is fixed at the drive side of the sensor.



Caution at permutation of drive side and measuring side.

- The cable connection can influence the torque measurement.
- At dynamic measurements, the measured value can be influenced by the inert masses of the housing.

Measuring side – see corresponding data sheet.

4.1 Sensors up to 15 N·m



Sensors with nominal torques up to 15 N·m are very sensitive regarding overload; therefore treat the sensors with great caution.

1. Connect the sensor electrically during the assembly and watch the signal; the measuring signal may not exceed the limit values.
2. Align the arrangement before the parts are firmly connected.
3. Mount the sensor at the **low torque resistance side** first, then at the stationary side. (This avoids impermissibly large torques from acting on the sensor.)
4. Counter-hold by hand, so that impermissibly large torques or disturbance variables can not act on the torque sensor.

4.2 Flange Connection

Before the assembly, flanges must be cleaned with dissolver (e.g. acetone), no foreign particles may adhere to them. The surface of the flange must indicate a evenness of at least 0.02 mm.

Tighten screws consistently. The flange may not slip while torque is applied (surface pressure), if necessary use fitting bolts.

4.3 Shaft Connection

The shafts must be cleaned with dissolver (e.g. acetone) before the assembly, no foreign particles may adhere to them.

The hub must fit corresponding to the connection.

4.4 Inside Square and Outside Square

The inside and outside square must be cleaned before the assembly. No foreign particles may adhere to them.

5 Electrical Connection

5.1 Pin Connection

6-pin	Function
1	SG- excitation -
2	SG- excitation +
3	Shield
4	SG- signal +
5	SG- signal -
6	100% calibration control

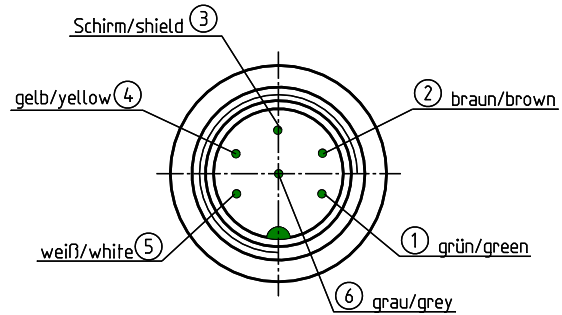

7-pin	Function
1	SG- excitation -
2	SG- excitation +
3	Shield
4	SG- signal +
5	SG- signal -
6	100% calibration control
7	-

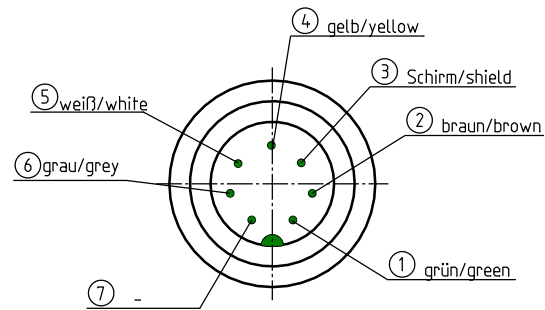

View: socket on soldering side

5.2 Free Cable Ends

Wire	Function
green	Excitation (-)
brown	Excitation (+)
yellow	Signal (+)
white	Signal (-)
grey	Control
netting	Shield

5.3 Cable

Only use a shielded cable with preferably small capacity. We recommend measuring cables from our product range. They have been tested in combination with our sensors and meet the metrological requirements.

5.4 Shielding Connection

In combination with the sensor and the external electronics, the shield forms a Faraday Cage. By this, electro-magnetic disturbances do not have any influence on the measurement signal. At potential difference problems we recommend to ground the sensor.

5.5 Extension Cable

Caution: depending on bridge resistance and wire cross section, the measuring cable length enters into the characteristic value of the sensor. Therefore order the sensor together with the extension cable.

Dependence of the characteristic value on the cable length:

Wire-cross section	Cable resistance per m	Deviation per m cable length at bridge resistance 350 Ω	Deviation per m cable length at bridge resistance 700 Ω	Deviation per m cable length at bridge resistance 1000 Ω
0,14 mm ²	0,28 Ω	0,08%	0,04%	0,028%
0,25 mm ²	0,16 Ω	0,046%	0,023%	0,016%
0,34 mm ²	0,12 Ω	0,034%	0,017%	0,012%

Cable resistance = 2 x resistance of the cable length (both feed lines of the sensor).

The sensors with the ordered cable length are calibrated together, Therefore the cable length does not need to be considered in this case.

5.6 Running of Measuring Cables

Do not run measuring cables together with control or heavy-current cables. Always assure that a large distance is kept to engines, transformers and contactors, because their stray fields can lead to interferences of the measuring signals.

If troubles occur through the measuring cable, we recommend to run the cable in a grounded steel conduit.

6 Measuring

6.1 Engaging

The warming-up period of the torque sensor is approx. 5 min. Afterwards the measurement can be started.



The warming-up period of the torque sensor is approx. 5 min.

6.2 Direction of Torque

Torque means clockwise or clockwise torque if the torque acts clockwise when facing the shaft end. In this case a positive electrical signal is obtained at the output.

Torque sensors can measure both clockwise and counter-clockwise direction.

6.3 Static / Quasi-Static Torques

Static and/or quasi-static torque is a slowly changing torque.

The calibration of the sensors occurs statically on a calibration device.

The applied torque may accept any value up to the nominal torque.

6.4 Dynamic Torques

6.4.1 General

The static calibration procedure of torque sensors is also valid for dynamic applications.

Note: The frequency of torques must be smaller than the natural frequency of the mechanical measurement setup.

The band width must be limited to 70 % of the nominal torque.

6.4.2 Natural Resonances

Estimate of the mechanical natural frequencies:

$$f_0 = \frac{1}{2 \cdot \pi} \cdot \sqrt{c \cdot \left(\frac{1}{J_1} + \frac{1}{J_2} \right)}$$

f_0 = Natural frequency in Hz
 J_1, J_2 = Moment of inertia in kg*m²
 c = Torsional rigidity in Nm/rad

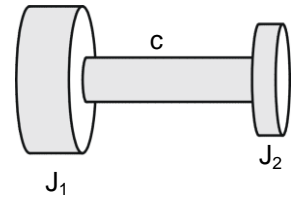

Operation of the device in natural resonance can lead to permanent damages.

6.5 Disturbance Variables

By disturbances, measured value falsifications can occur by

- Vibrations,
- Temperature gradients in the torque sensor,
- Temperature changes,
- Electrical disturbances,
- Magnetic disturbances,
- EMC (electromagnetic disturbances),

Therefore avoid these disturbance variables by decoupling of vibrations, covers, etc.

6.6 Calibration Control (Option)

By a control resistance, a signal is generated in the sensor which corresponds to the nominal value of the sensor.

Advantage:

Re-Calibrations are reduced. Before each measurement the zero point and the nominal value can be checked.

Function:

By applying positive SG supply, the measuring bridge is electrically detuned, so that at the output a measuring signal of 100% of the nominal value is available.

Optionally 50%, 80% possible.

Use calibration control at unloaded torque sensor, only.

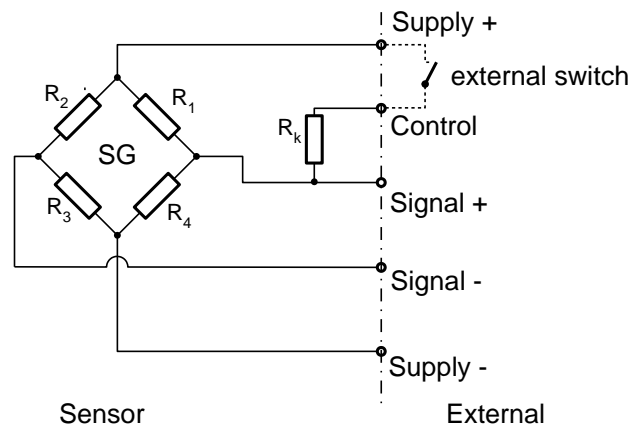

7 Maintenance

7.1 Maintenance Schedule

Action	Frequency	Date	Date	Date
Control of cables and connectors	1x p.a.			
Calibration	< 26 months			
Control of fixation (flanges, shafts)	1x p.a.			

7.2 Trouble Shooting

This chart is used for searching for the most frequent errors and their elimination.

Problem	Possible Cause	Trouble Shooting
No signal	No sensor excitation	<ul style="list-style-type: none"> • Outside of permissible range • Connect excitation • Cable defect • No mains supply
	Signal output connected wrong	<ul style="list-style-type: none"> • Connect output correctly • Evaluation electronics defect
Sensor does not react to torque	Shaft not clamped	<ul style="list-style-type: none"> • Clamp correctly
	No power supply	<ul style="list-style-type: none"> • Outside of permissible range • Connect supply • Cable defect • No mains supply
	Cable defect	<ul style="list-style-type: none"> • Repair cable
	Connector connected wrong	<ul style="list-style-type: none"> • Connect correctly
Signal has dropouts Zero point outside of tolerance	Cable defect	<ul style="list-style-type: none"> • Repair cable
	Cable defect	<ul style="list-style-type: none"> • Repair cable
	Shaft mounted distorted	<ul style="list-style-type: none"> • Mount correctly
	Distorted shaft string	<ul style="list-style-type: none"> • Release from distortion
	Strong lateral forces	<ul style="list-style-type: none"> • Reduce lateral forces
Wrong torque indication	Shaft overloaded	<ul style="list-style-type: none"> • Send to manufacturer
	Calibration not correct	<ul style="list-style-type: none"> • Re-calibrate
	Sensor defect	<ul style="list-style-type: none"> • Repair by manufacturer
	Torque shunt	<ul style="list-style-type: none"> • Eliminate shunt

8 Decommission

- All sensors must be dismantled professionally.
- Do not strike sensor housings with tools.
- Do not apply bending moments on the sensor, e.g. through levers.
- The torque sensor must be supported to avoid falling down during the dismantling.

9 Transportation and Storage

The transportation of the sensors must occur in suitable packing. For smaller sensors, stable cartons which are well padded are sufficient (e.g., air cushion film, epoxy crisps, paper shavings). The sensor should be tidily packed into film. Larger sensors should be packed in cases.

9.1 Transportation

Only release well packed sensors for transportation. The sensor should not be able to move back and forth in the packing. The sensors must be protected from moisture.

Only use suitable means of transportation.

9.2 Storage

The storage of the sensors must occur in dry, dust-free rooms, only. Slightly lubricate shafts and flanges with oil before storing (rust).

10 Disposal

The torque sensors must be disposed according to the valid provisions of law.

11 Calibration

At the time of delivery, torque sensors have been adjusted and tested with traceable calibrated measuring equipment at factory side. Optionally, a calibration of the sensors can be carried out.

11.1 Proprietary Calibration

Acquisition of measurement points and issuing of a calibration protocol Traceable calibrated measuring equipment is being used for the calibration. The sensor data are being checked during this calibration.

11.2 DKD-Calibration

The calibration of the sensor is carried out according to the guidelines of the DKD. The surveillance of the calibrating-laboratory takes place by the DKD. At this calibration, the uncertainty of measurement of the torque measuring instrument is determined. Further information can be obtained upon request.

11.3 Re-Calibration

The recalibration of the torque sensor should be carried out after 26 months at the latest. Shorter intervals are appropriate:

- Overload of the sensor
- After repair
- After inappropriate handling
- Demand of high-quality standards
- Special traceability requirements

12 Data Sheet

See www.interfaceforce.com