

The ICT800 Contactless In-Cylinder Linear Transducer combines the best features associated with LVDTs and potentiometers into one rugged, contactless and highly reliable displacement transducer.

Signal conditioning is integrated into the transducer flange. Operating from 8 - 30Vdc or 5Vdc supply, the electronics provide an analogue voltage output signal of either 0.5-4.5Vdc or 0.2-4.8Vdc over the selected measurement range.

With a transducer body diameter of only 8mm the **ICT800** is ideal for installation into hydraulic and pneumatic cylinder applications where space is at a premium. The **ICT800** is ideal for use on small-bore actuators and offers a choice of internal or threaded external flange mounting configurations to suit tie-rod, welded and rear clevis-mounted cylinder types in stroke ranges **from 25 to 1000mm**.

Two core configurations also provide the designer the following options:

SLEEVED CORE - cylinder rods can be simply machined to accommodate the sleeve.

This also gives the option of retro-fitting existing servo-cylinders with an upgrade to ICT technology.

THREADED CORE - provides the designer with the minimum transducer body size and simplified installation requiring minimal machining.

With no electrical sliding contacts, the **ICT800** has a working life which is almost limitless.



Key Features

- Measurement range 25-1000mm
- Small transducer body length to stroke ratio
- 12bit resolution
- Absolute measurement
- Working pressure to 670 Bar (10,000 psi)
- Temperature range -40 to +125°C
- Operates from 5Vdc or 8-30Vdc
- Analog output – 0.5-4.5Vdc or 0.2-4.8Vdc
- Flexible mounting styles
- Rugged stainless steel construction

ICT800 ANALOG OUTPUT IN-CYLINDER LINEAR TRANSDUCER

METRIC
IF IN DOUBT ASK

All specification data on this drawing has been tested and documented by Penny & Giles unless otherwise stated.
The qualification and suitability of this product in any customer specific application is the responsibility of the customer unless otherwise agreed with Penny & Giles.

ISS	DATE	DRAWN	ECR No.	CHK	APP
5A	22/05/13	S.H.	10835/9	M.B.	M.B.

CUSTOMER SELECTABLE FLANGE, CONNECTION AND CORE MOUNTING OPTIONS

EXTERNAL HEX FLANGE
BXX-CABLE EXIT
ORDERING CODE
ICT800/E/S/-----/BXX

SEE ORDERING CODE

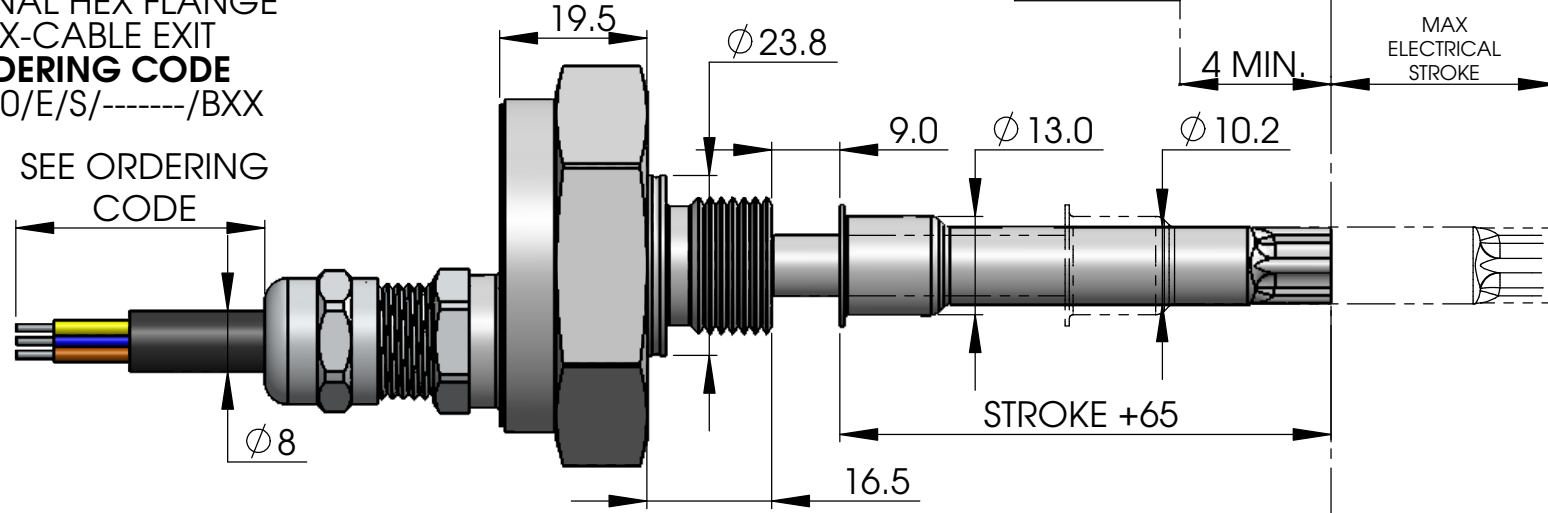

DETAIL A
SCALE 2 : 1.5

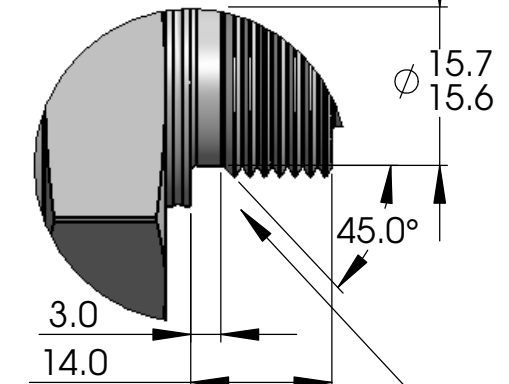

(THE DETAILS IN THIS REGION CONFORM TO ISO6149/2 M18 X 1.5 FOR WHICH PORT CUTTERS ARE AVAILABLE)

EXTERNAL HEX FLANGE
C01-M12 CONNECTOR
ORDERING CODE
ICT800/E/T/-----/C01

M12 5 PIN MALE SOCKET

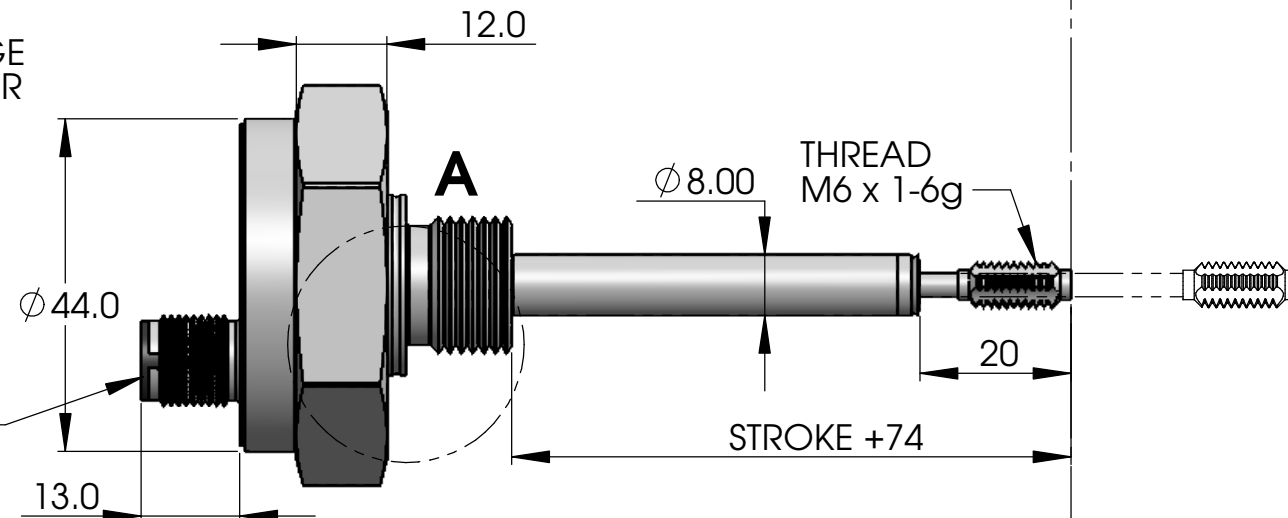

DETAIL B
SCALE 2 : 1.5

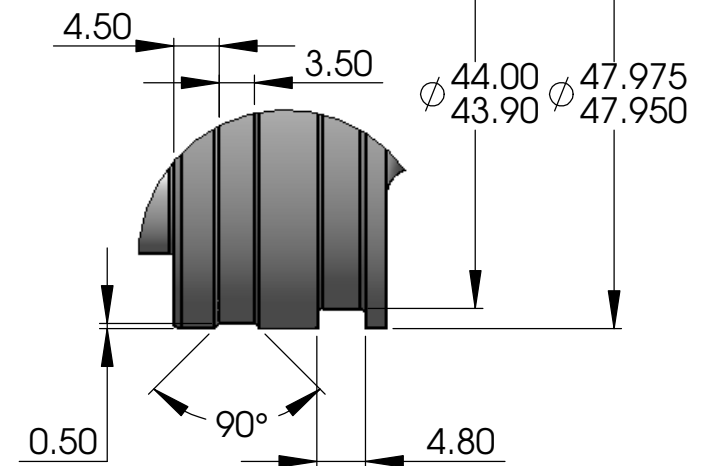

FOR SUGGESTED INSTALLATION DIMENSIONS, REFER TO AI209399

INTERNAL FLANGE
FXX CABLE EXIT
ORDERING CODE
ICT800/I/S/-----/FXX

SEE ORDERING CODE

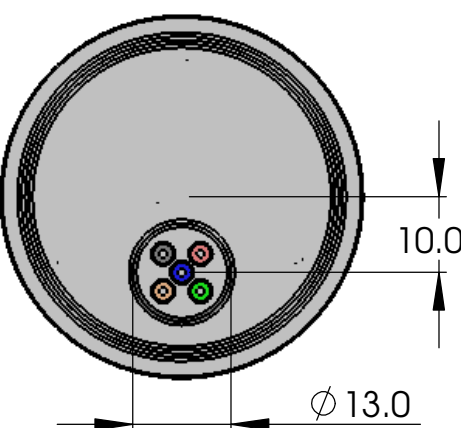
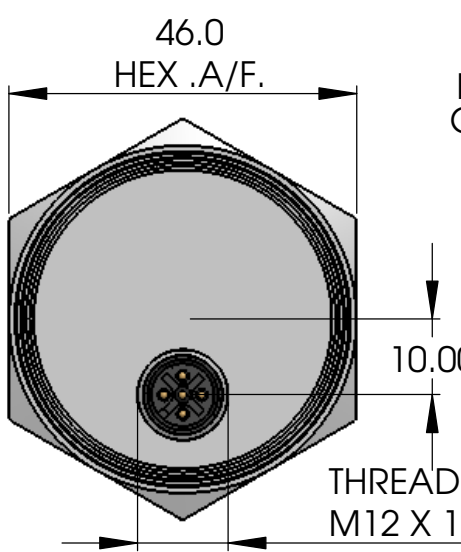
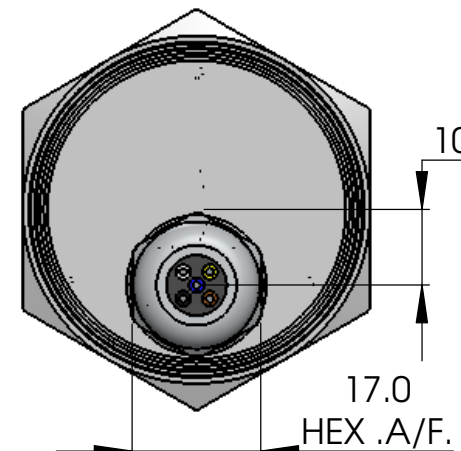
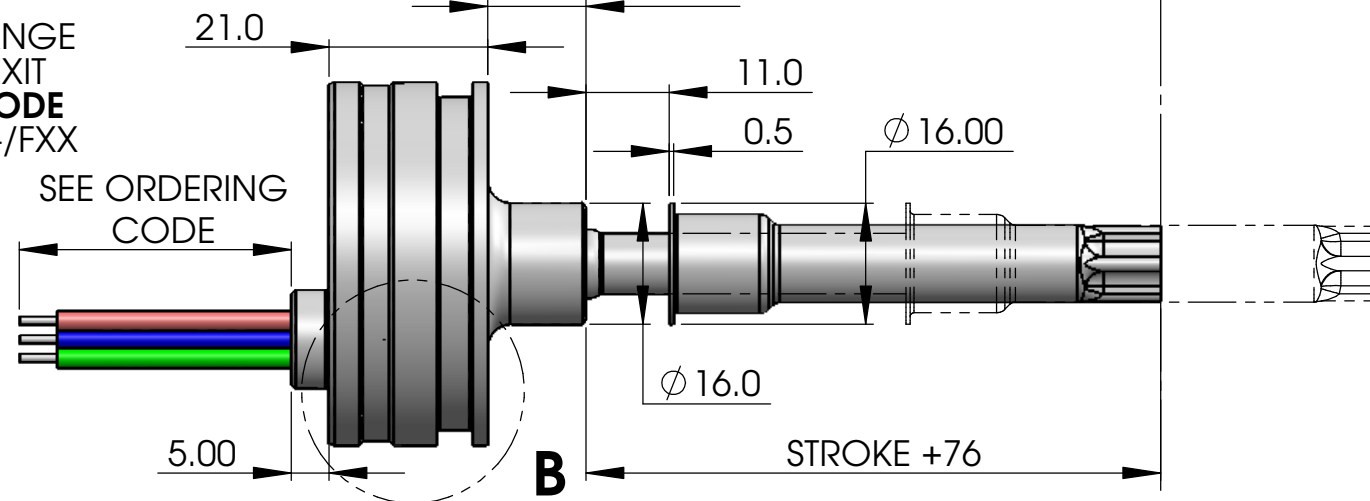

SCALE 1:1 UNLESS STATED	IF CONTROL DIMENSIONS (Kc) ARE SPECIFIED THEY ARE TO BE SUBJECT TO 100% INSPECTION OR STATISTICAL PROCESS CONTROL	D No ICT800	MATERIAL STAINLESS STEEL	TOLERANCES: IN-LINE WITH PENNY & GILES STANDARDS 55-301 SURFACE TEXTURE VALUES IN MICROMETRES (µm) TO BS1134:PT2. ALL MACHINED SURFACES TO BE 1.6	TITLE IN CYLINDER TRANSDUCER	 A Curtiss-Wright Company PART NUMBER: ICT800	A3 SHT 1 OF 3 SHTS
THIRD ANGLE PROJECTION TO BS 8888	MASS (g)	FIRST USED ON	FINISH CLEAN	ALL SCREW THREADS TO BS3643 PT.2: EXTERNAL CLASS: 6g INTERNAL CLASS: 6H ANGULAR ± 1° LINEAR (MACHINING) 0, mm +/- 0.5 mm 0,0 mm +/- 0.2 mm 0,00mm +/- 0.1mm 0,000mm +/- 0.01mm BREAK EDGE 0.05 - 0.15mm FILLET RADS 0.1 - 0.3mm UNLESS OTHERWISE STATED	REF. REF.		

PERFORMANCE

OUTPUT OPTIONS (A1) 0.5 Vdc TO 4.5Vdc
(A5) 0.2 Vdc TO 4.8Vdc

LOAD RESISTANCE 1K Ω MINIMUM (RESISTIVE TO GROUND)

OUTPUT NOISE <1 mVrms

INPUT/OUTPUT DELAY <10mS

FREQUENCY RESPONSE 100Hz @ -3dB

NON-LINEARITY <± 0.1%

TEMPERATURE COEFFICIENT <±300ppm/°C

SUPPLY VOLTAGE (Vdc) 8 TO 30Vdc UNREGULATED
5Vdc ±0.1Vdc REGULATED*
*(OUTPUT WILL FOLLOW INPUT VARIATIONS)

OVER VOLTAGE PROTECTION 40Vdc MAX

MAXIMUM SUPPLY CURRENT <80mA

REVERSE POLARITY PROTECTION YES

SHORT CIRCUIT PROTECTION YES ALL CONNECTIONS (EXCEPT VS SUPPLY TO OUTPUT 10V MAX)

POWER ON SETTLEMENT TIME <1S

RESOLUTION 12 BITS

ACTUAL ELECTRICAL STROKE = HIGH VOLTAGE POSITION – LOW VOLTAGE POSITION (SEE FIG 1)

**SEE ORDERING CODE
OUTPUT LAW EXAMPLE
FOR MAX ELECTRICAL STROKE
1000 mm SENSOR - A5 OUTPUT**

	LOW VOLTAGE POSITION	HIGH VOLTAGE POSITION	ACTUAL ELECTRICAL STROKE
1	0000	1000	1000
2	1000	0000	1000
3	0300	0700	0400
4	0600	0000	0600

NOTE:
NON STANDARD
OUTPUT LAWS
AVAILABLE
I.E. SWITCH OUTPUTS

FIGURE 1

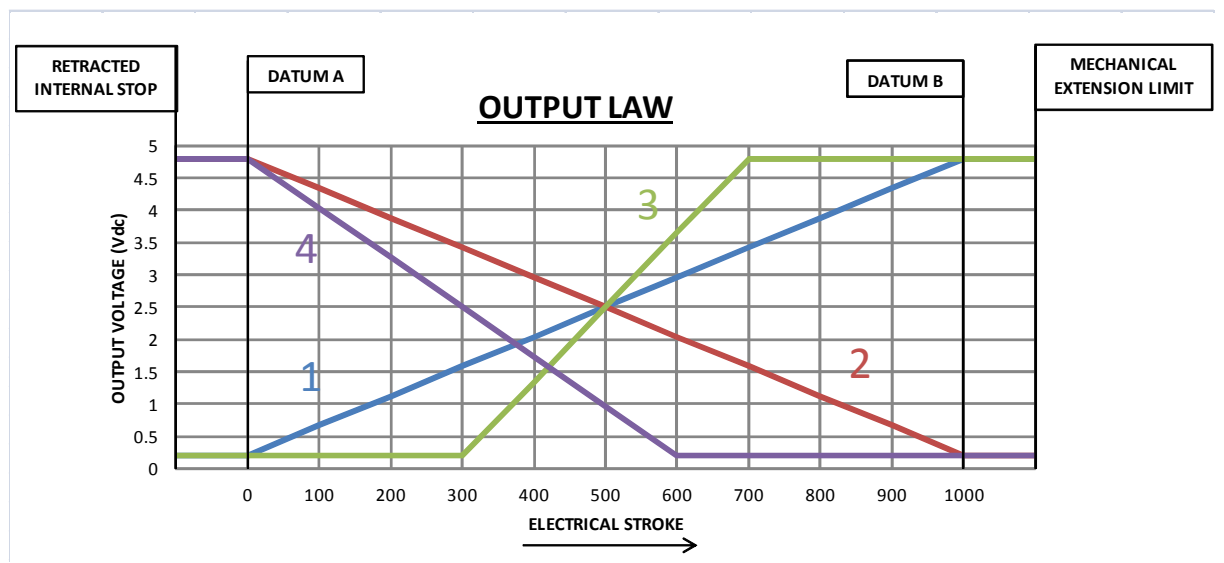

ANALOGUE VOLTAGE OUTPUT OPTION A1 (0.5V – 4.5V)

VOLTAGE OUTPUT RANGE ABSOLUTE VOLTAGE 0.5 TO 4.5Vdc OVER MEASUREMENT RANGE (±0.2%)

ANALOGUE VOLTAGE OUTPUT OPTION A5 (0.2V – 4.8V)

VOLTAGE OUTPUT RANGE ABSOLUTE VOLTAGE 0.2 TO 4.8Vdc OVER MEASUREMENT RANGE (±0.2%)

EMC DIRECTIVE 2004/108/EC

OPERATIONAL TEMPERATURE RANGE -40°C TO +125°C

STORAGE TEMPERATURE RANGE -40°C TO +85°C

LIFE CONTACTLESS

VELOCITY MAX 2m/s IN HYDRAULIC APPLICATIONS (ISO VG32 MINERAL OIL)

VIBRATION BS EN 60068-2-64 (9 gn RMS)

SHOCK 2500g SURVIVAL

PRESSURE – WORKING 670 BAR

BURST 1000 BAR

PULSED 0 TO 470 BAR IN 1 SECOND (TESTED TO 100,000 CYCLES)

WORKING FLUIDS COMPATIBLE WITH A WIDE RANGE OF HYDRAULIC FLUIDS – INCLUDING MINERAL, SYNTHETIC, FIRE RETARDANT AND ECO BASED FLUIDS.

SEALING FOR SEALING INFORMATION SEE SHEET 3.

MTTFd 203 YEARS

NOTE: FOR OPTIMUM PERFORMANCE SUPPLY GROUND NEEDS TO BE CONNECTED TO SENSOR CASE OR SENSOR CASE CONNECTED TO SYSTEM GROUND

ORDERING CODE - ICT800/ -/ -/ ----/ ----/ ----/ --/ ---

FLANGE.....

I - INTERNAL

E - EXTERNAL

CORE OPTION.....

S - SLEEVE

T - THREADED

MAX ELECTRICAL STROKE.......

25 mm TO 1000 mm
(25 TO 200 IN 5 mm INCREMENTS
210 TO 1000 IN 10 mm INCREMENTS)

LOW VOLTAGE OUTPUT POSITION FROM DATUM A.....

DEFAULT - 0000 mm (SEE FIG 1)

HIGH VOLTAGE OUTPUT POSITION FROM DATUM A.....

DEFAULT - MAX ELECTRICAL STROKE (SEE FIG 1)

OUTPUT.....

A1 - 0.5V TO 4.5V

A5 - 0.2V TO 4.8V

CONNECTIONS.....

SEE CONNECTOR + CABLE CONNECTIONS

C01 - M12 CONNECTOR

BXX - CABLE GLAND + CABLE LENGTH

FXX - FLYLEADS + LENGTH

SCALE /	IF CONTROL DIMENSIONS (Kc) ARE SPECIFIED THEY ARE TO BE SUBJECT TO 100% INSPECTION OR STATISTICAL PROCESS CONTROL.	D No ICT800	MATERIAL /	TOLERANCES: IN-LINE WITH PENNY & GILES STANDARDS 55-301 SURFACE TEXTURE VALUES IN MICROMETRES (µm) TO BS1134:PT2. ALL MACHINED SURFACES TO BE 1.6	TITLE IN CYLINDER TRANSDUCER	 A Curtiss-Wright Company	A3
UNLESS STATED		FIRST USED ON		ALL SCREW THREADS TO BS3643 PT2: EXTERNAL CLASS: 6g INTERNAL CLASS: 6H		PART NUMBER: ICT800	SHT 2 OF 3 SHTS
	MASS (g)	VOL. (mm ³)	REF.	FINISH			
	/	/	/	/			

METRIC
IF IN DOUBT ASK

All specification data on this drawing has been tested and documented by Penny & Giles unless otherwise stated.
The qualification and suitability of this product in any customer specific application is the responsibility of the customer unless otherwise agreed with Penny & Giles.

ISS	DATE	DRAWN	ECR No.	CHK	APP
5A	22/05/13	S.H.	10835/9	M.B.	M.B.

CONNECTOR AND CABLE CONNECTIONS

C01 - M12 CONNECTOR - IP67

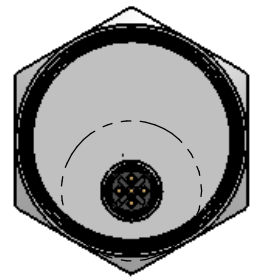

D

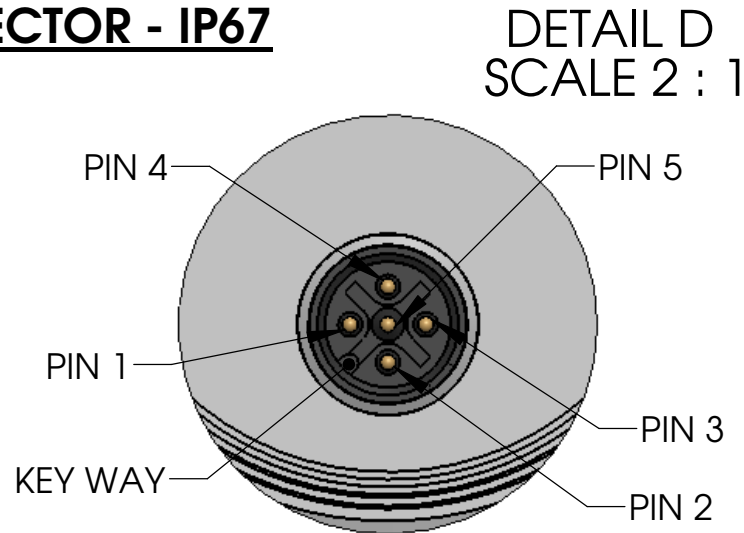

DETAIL D
SCALE 2 : 1

PIN 1	VOUT
PIN 2	VSUPPLY
PIN 3	GROUND
PIN 4	N/C
PIN 5	N/C

MATING CONNECTOR AVAILABLE

- SA210517/MK1 = 1 m LONG
- SA210517/MK5 = 5 m LONG
- SA210517/MK10 = 10 m LONG

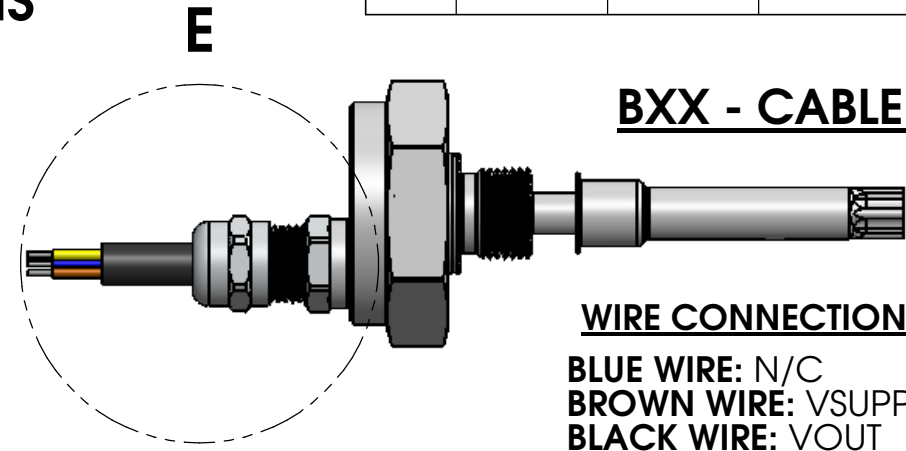
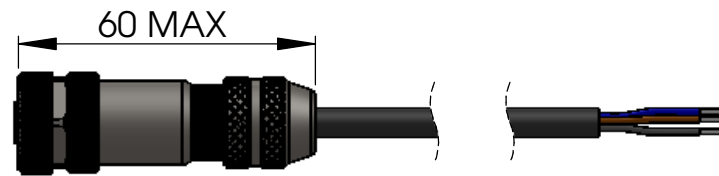

BXX - CABLE - IP69K

WIRE CONNECTIONS

- BLUE WIRE: N/C
- BROWN WIRE: VSUPPLY
- BLACK WIRE: VOUT
- WHITE WIRE: N/C
- GREY: GROUND

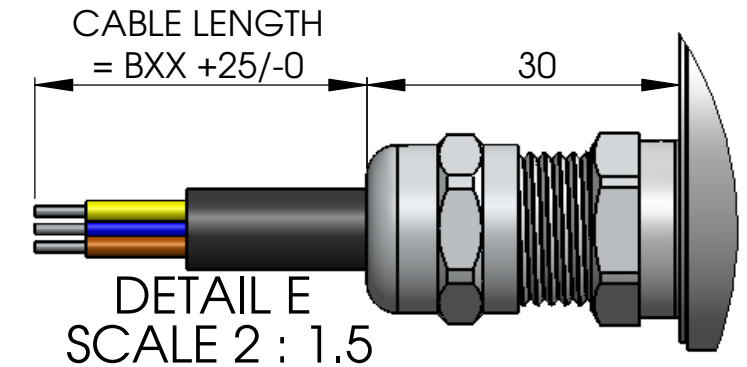

DETAIL E
SCALE 2 : 1.5

ORDERING CODES
B01 = 01 m CABLE MIN
B06 = 06 m CABLE MAX
IN 1 m INCREMENTS

C FXX - FLYLEADS - IP66

ORDERING CODES
FP2 = 200 mm FLYLEADS
FP5 = 500 mm FLYLEADS
F01 = 1 m FLYLEADS

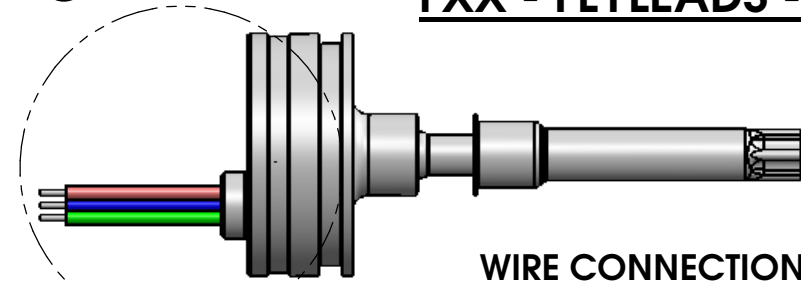

WIRE CONNECTIONS

- BLUE WIRE: N/C
- BROWN WIRE: VSUPPLY
- BLACK WIRE: VOUT
- RED WIRE: N/C
- GREEN WIRE: GROUND

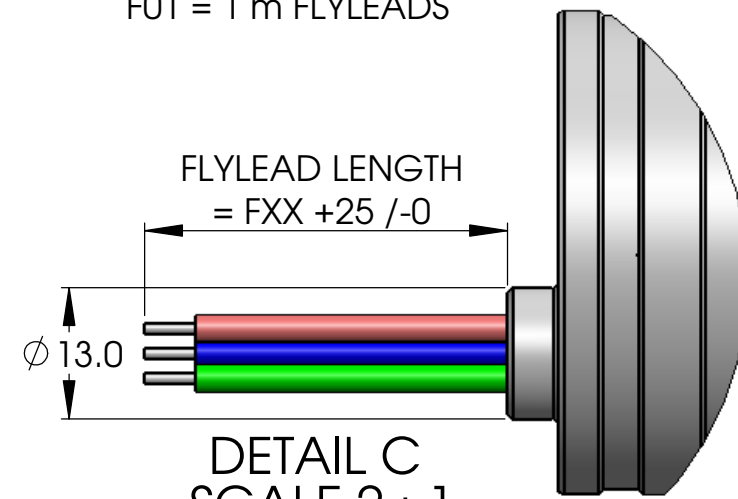

DETAIL C
SCALE 2 : 1

ICT800 MATERIALS USED

<p>ALL VARIANTS:</p> <p>STAINLESS STEEL 316 - BODY (CASE) SLEEVE GUIDE TUBE</p> <p>STAINLESS STEEL 303 - FLANGE</p> <p>ALLOY 52 - CORE</p> <p>HNBR- 'O'-RINGS</p>	<p>BXX OPTION:</p> <p>NICKLE PLATED BRASS - CABLE GLAND</p> <p>FPM - CABLE GLAND SEAL</p> <p>PUR/PVC - CABLE</p>	<p>C01 OPTION:</p> <p>PA66 CONNECTOR INSERT</p> <p>NBR 'O' RING</p> <hr/> <p>FXX OPTION:</p> <p>SILICONE RUBBER - CABLE SEAL</p>
--	---	--

SCALE 1:1.5 UNLESS STATED	IF CONTROL DIMENSIONS (Kc) ARE SPECIFIED THEY ARE TO BE SUBJECT TO 100% INSPECTION OR STATISTICAL PROCESS CONTROL	D No ICT800	MATERIAL /	TOLERANCES: IN-LINE WITH PENNY & GILES STANDARDS 55-301 SURFACE TEXTURE VALUES IN MICROMETRES (µm) TO BS1134:PT2. ALL MACHINED SURFACES TO BE 1.6	TITLE IN CYLINDER TRANSDUCER	 A Curtiss-Wright Company PART NUMBER: ICT800	A3 SHT 3 OF 3 SHTS
THIRD ANGLE PROJECTION TO BS 8888	MASS (g) /	VOL. (mm ³) /	FINISH /	<p>ALL SCREW THREADS TO BS3643 PT2: EXTERNAL CLASS: 6g INTERNAL CLASS: 6H</p> <p>ANGULAR ± 1°</p> <p>LINEAR (MACHINING) 0, mm +/- 0.5 mm 0,0 mm +/- 0.2 mm 0,00mm +/- 0,1mm 0,000mm +/- 0,01mm</p> <p>BREAK EDGE 0.05 - 0.15mm FILLET RADS 0.1 - 0.3mm</p> <p>UNLESS OTHERWISE STATED</p>			



www.pennyandgiles.com

Penny & Giles

Position sensors, joysticks and solenoids for commercial and industrial applications.

15 Airfield Road
Christchurch
Dorset BH23 3TG
United Kingdom
+44 (0) 1202 409499
+44 (0) 1202 409475 Fax
sales@pennyandgiles.com

36 Nine Mile Point Industrial Estate
Cwmfelinfach
Gwent NP11 7HZ
United Kingdom
+44 (0) 1495 202000
+44 (0) 1495 202006 Fax
sales@pennyandgiles.com

665 North Baldwin Park Boulevard
City of Industry, CA 91746
USA
+1 626 480 2150
+1 626 369 6318 Fax
us.sales@pennyandgiles.com

Straussenlettenstr. 7b
85053 Ingolstadt,
Germany
+49 (0) 841 885567-0
+49 (0) 841 885567-67 Fax
info@penny-giles.de

No. 116, Sumu Road,
Suzhou Industrial Park,
Jiangsu, 215021
China
+86 512 6287 3380
+86 512 6287 3390 Fax
sales@pennyandgiles.com.cn

The information contained in this brochure on product applications should be used by customers for guidance only. Penny+Giles Controls Ltd makes no warranty or representation in respect of product fitness or suitability for any particular design application, environment, or otherwise, except as may subsequently be agreed in a contract for the sale and purchase of products. Customer's should therefore satisfy themselves of the actual performance requirements and subsequently the products suitability for any particular design application and the environment in which the product is to be used.

Continual research and development may require change to products and specification without prior notification. All trademarks acknowledged.

© Penny+Giles Controls Ltd 2013

Innovation In Motion

**CURTISS
WRIGHT** **Controls**
Industrial