

- **No-contact, Hall-effect technology**
- **Wear free – unlimited mechanical life**
- **Simple mounting, low-profile design**
- **Measurement angle 20-360°**
- **5V or 9-30V supply options**
- **Dual redundant outputs**
- **Analog output – 0.5-4.5V or 0.2-4.8V**
- **PWM output option**
- **Fail-safe outputs**
- **Sealing to IP69K**
- **Flying leads**



The NRH300DP is a no-contact, Rotary Position Sensor that offers the optimal combination of performance, safety and cost. The sensor utilises proven Hall-effect, sensing technology in a low-profile (8mm) housing with separate magnet for true no-contact sensing.

The electrical output span can be set to correspond to rotations of 20° to 360°, and the positional information is determined by the angle of the supplied magnet relative to the sensor body. The maximum air gap between magnet and sensor is 5.5mm, while concentric offsets of up to 2mm can be tolerated with minimal impact on output linearity. The magnet can be supplied in a convenient carrier, housed in a bolt, as a plug or loose.

Innovative circuit design allows the sensor to be powered from a regulated 5V supply or a varying voltage in the range of 9-30V, such as a vehicle's battery.

To enhance system performance, the NRH300DP has a second, redundant output that can be used for error checking in safety-critical applications. The versatile, factory-programmable electronics can be easily set to one of two analog voltage output ranges or one of three PWM frequencies. In addition, the polarities of each of the analog outputs can be independently set. On-board diagnostic functions ensure the outputs are put into safe, pre-defined states should an internal sensor error be detected.

The sealed design offers exceptional levels of performance with respect to water and dust, shock, vibration and temperature, meaning the sensor is ideal for use in hostile, on- and off-highway vehicle environments.

Connection to the sensor is with simple flying leads for customer termination.



CONTENTS

Configuration & Ordering Codes.....	3
Measurement Angle	3
Output	3
Direction	4
Magnet	4
Cable	4
Installation	5
Mechanical	5
Sensor	5
Magnet	6
Electrical Connections.....	7
Flying Leads.....	7
Specifications.....	8
Electrical.....	8
Voltage Outputs	9
PWM Outputs.....	10
Mechanical	11
Environmental	11

© 2015 Curtiss-Wright. All rights reserved.

Curtiss-Wright accepts no responsibility for possible errors in catalogs, brochures and other printed material. Curtiss-Wright reserves the right to alter its products without prior notice. This also applies to products already ordered provided that such alterations can be made without affecting agreed specifications.
All trademarks in this material are properties of their respective owners.



CONFIGURATION & ORDERING CODES

NRH300DP-XXX-XX-X-X-XX

Type	Measurement Angle	Output	Direction	Magnet	Cable
NRH300DP	XXX	XX	X	X	XX
	XXX	A1	3	O	P5
		A5	4	B	
		P1	5	P	
		P2	6	M	
		P3			

MEASUREMENT ANGLE

NRH300DP-XXX-XX-X-X-XX

Code	Description
XXX	20-360° in 1° increments

OUTPUT

NRH300DP-XXX-XX-X-X-XX

Code	Description
A1	Analog voltage: 10-90% of 5V supply or 0.5-4.5V of 9-30V supply
A5	Analog voltage: 4-96% of 5V supply or 0.2-4.8V of 9-30V supply
P1	PWM: 244Hz
P2	PWM: 500Hz
P3	PWM: 1kHz



DIRECTION

NRH300DP-XXX-XX-X-X-XX

Code	Description
3	Both clockwise
4	Both anti-clockwise
5	Output 1 clockwise, Output 2 anti-clockwise
6	Output 1 anti-clockwise, Output 2 clockwise

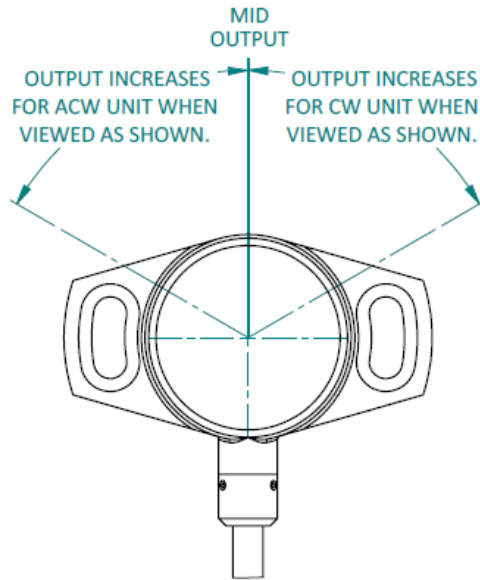

MAGNET

NRH300DP-XXX-XX-X-X-XX

Code	Description
O	Molded carrier
B	Bolt-type carrier
P	Plug-type carrier
M	Magnet only

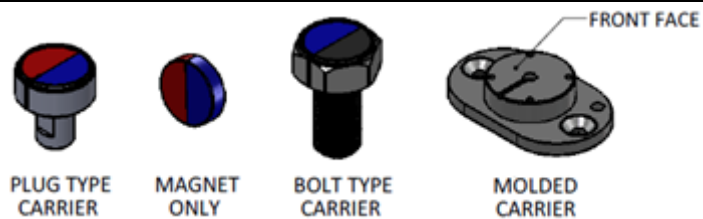

CABLE

NRH300DP-XXX-XX-X-X-XX

Code	Description
P5	0.5m length, 24AWG flying leads



INSTALLATION

MECHANICAL

Sensor

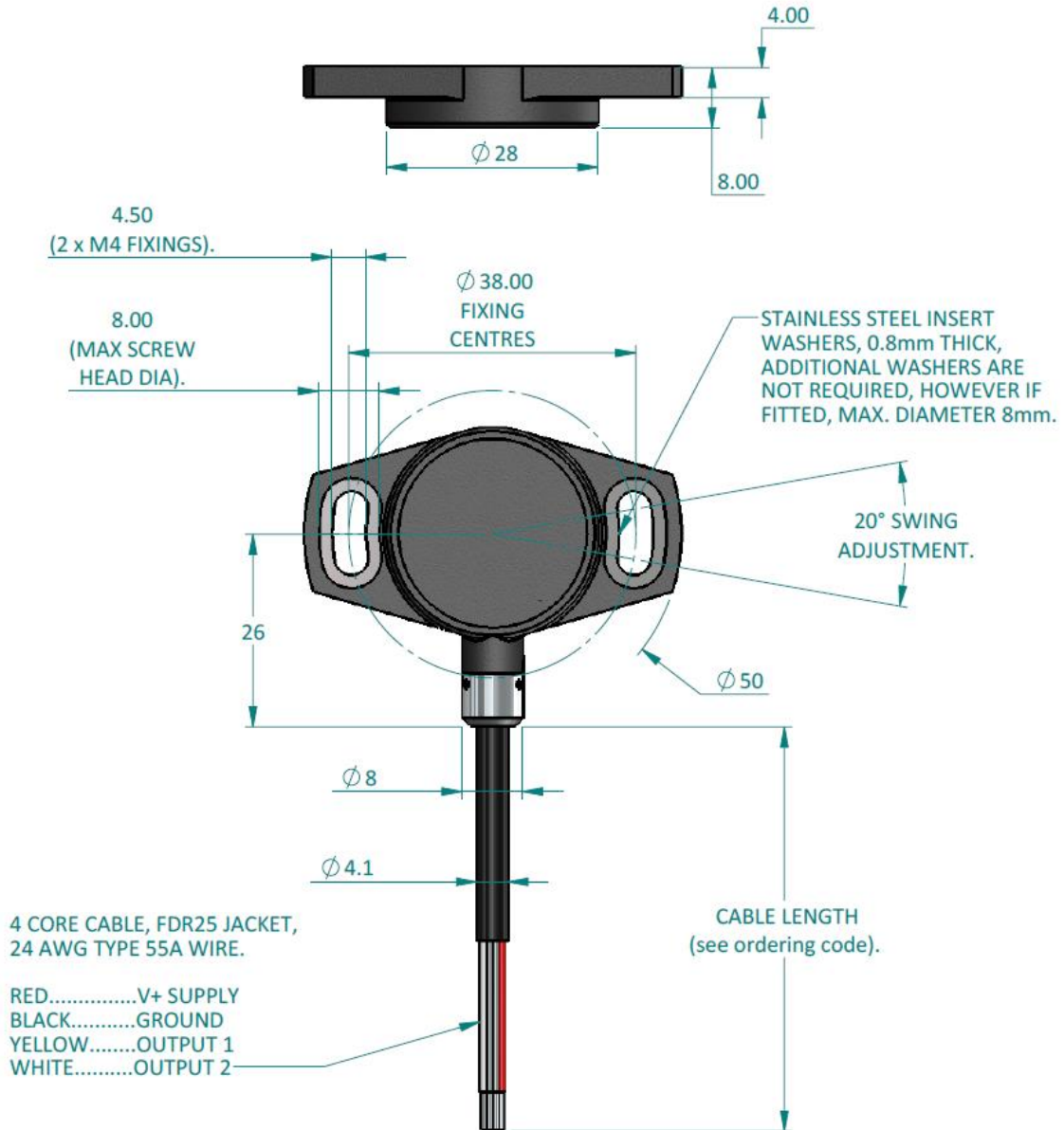

Dimensions in mm



Magnet

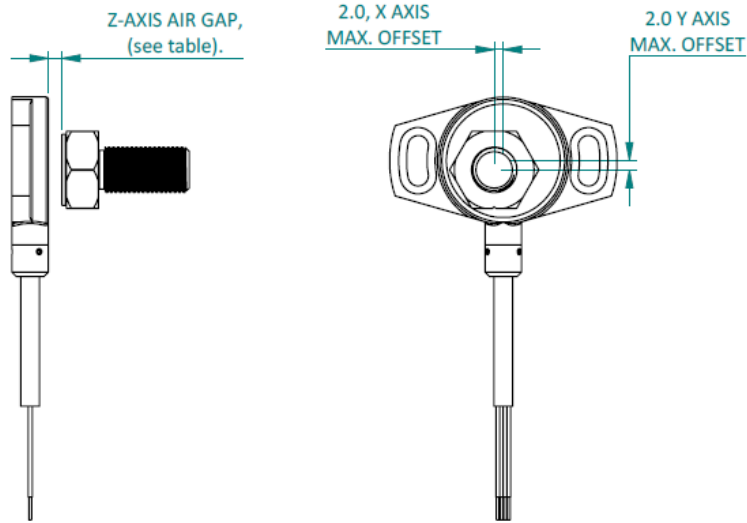

Dimensions in mm

Magnet Type	Air Gap
MOLDED CARRIER	1.5-6.5mm from front face of carrier
BOLT & PLUG TYPE	2-7mm
MAGNET ONLY	3-8mm

NOTE

All stated specifications are based on a nominal air gap of 3.5mm. Per the table above, other air gaps are possible but some specifications may vary. Please consult Curtiss-Wright for further details.
 If the unit is operated when the magnet is outside the recommended air gap, the output will not meet specification. If the magnet is absent, the output will default to <0.1Vdc or a 0% PWM duty cycle.

Molded Carrier

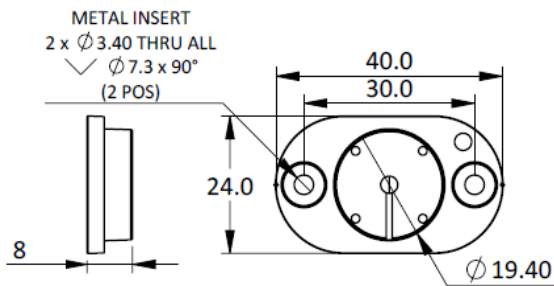

Bolt Type

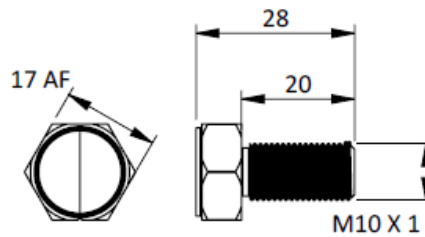

Plug Type

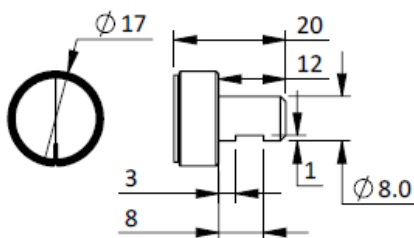

Magnet Only

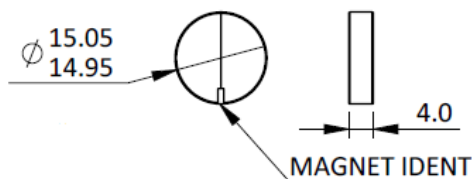



ELECTRICAL CONNECTIONS

Flying Leads

Color	Function
RED	Vsupply
BLACK	GND (0V)
YELLOW	Output 1
WHITE	Output 2



SPECIFICATIONS

ELECTRICAL

MEASUREMENT RANGE	20-360° in 1° increments
SUPPLY VOLTAGE	5Vdc \pm 0.5Vdc or 9-30Vdc unregulated
SUPPLY CURRENT	<25mA
SUPPLY REVERSE POLARITY PROTECTION	Yes
SHORT-CIRCUIT PROTECTION TO GND	Yes
SHORT-CIRCUIT PROTECTION TO SUPPLY	When used with 5V supply only
OVER-VOLTAGE PROTECTION	Up to 40Vdc (-40°C to +60°C)
POWER-ON SETTLEMENT	<1s
RESOLUTION	12-bit (0.025% of measurement range)
LINEARITY (ABSOLUTE)	< \pm 0.4%

Linearity versus magnetic misalignment

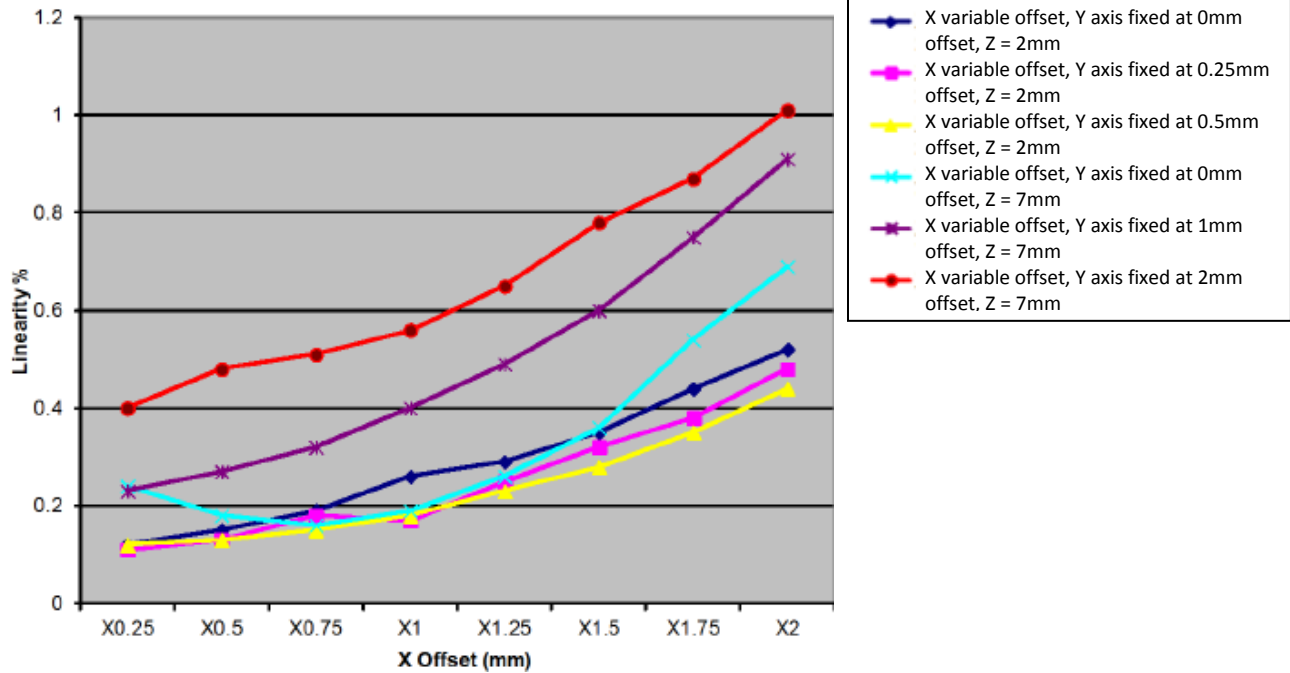

TEMPERATURE COEFFICIENT	< \pm 50ppm /°C in 5Vdc mode, < \pm 100ppm /°C in 9-30Vdc mode
-------------------------	--



VOLTAGE OUTPUTS

OUTPUT RANGE A1 (5Vdc SUPPLY)	10-90% $\pm 1\%$ of V_{supply} over measurement range
OUTPUT RANGE A1 (9-30Vdc SUPPLY)	0-5-4.5V $\pm 3\%$ absolute over measurement range
MONOTONIC RANGE	5%/0.25V to 95%/4.75V nominal
OUTPUT RANGE A5 (5Vdc SUPPLY)	4-96% $\pm 1\%$ of V_{supply} over measurement range
OUTPUT RANGE A5 (9-30Vdc SUPPLY)	0.2-4.8V $\pm 3\%$ absolute over measurement range
MONOTONIC RANGE	2%/0.1V to 98%/4.9V nominal

Voltage output law examples

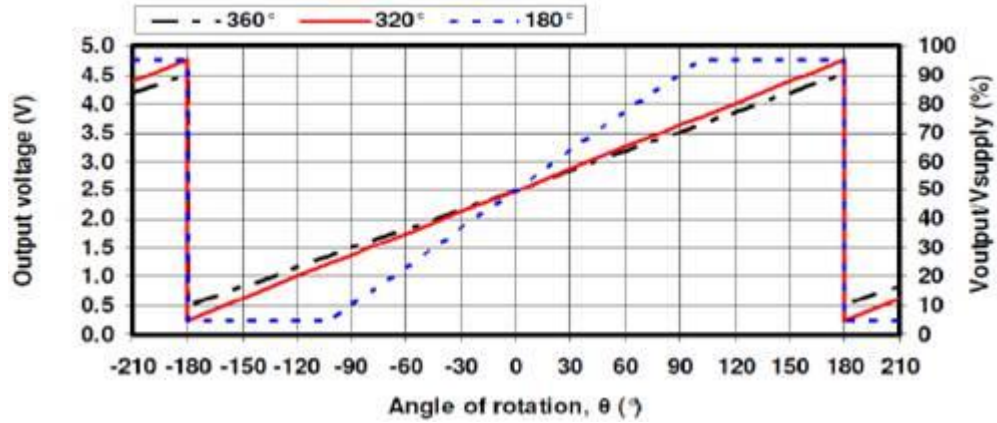

LOAD RESISTANCE	10k Ω min. (resistive to GND)
OUTPUT NOISE	<1mV rms
INPUT/OUTPUT DELAY	<2ms



PWM OUTPUTS

PWM FREQUENCY	244Hz, 500Hz or 1kHz ±20%
PWM LEVELS (5Vdc SUPPLY)	0V and Vsupply ±1%
PWM LEVELS (9-30Vdc SUPPLY)	0V and 5V ±3% nominal
DUTY CYCLE	10-90% over measurement range
MONOTONIC RANGE	5-95% nominal
LOAD RESISTANCE	10kΩ min. (resistive to GND)
RISE/FALL TIME	<15μs typical

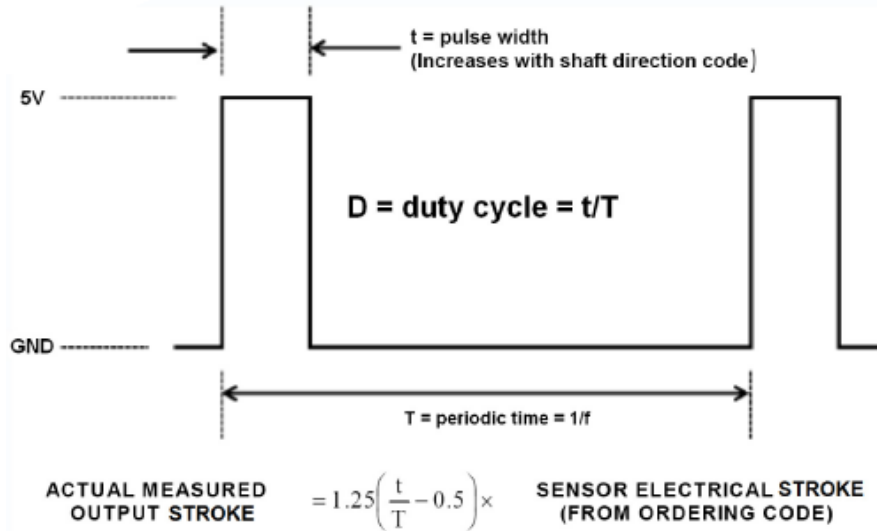

**MECHANICAL**

MECHANICAL ANGLE	360° continuous
MAXIMUM OPERATING SPEED	3600°/s
WEIGHT	<45g
MOUNTING	2x M4 screws, recommended tightening torque 2.0Nm
CABLE	4-core cable, FDR25 jacket, 24 AWG Spec 55A wires

ENVIRONMENTAL

OPERATING TEMPERATURE RANGE	-40°C to 120°C
STORAGE TEMPERATURE RANGE	-40°C to 120°C
SEALING	IP68, IP69K
VIBRATION	BS EN 60068-2-64:2008 section 8.4 (31.4gn rms) 20-2000Hz random
SHOCK	2500g
LIFE	Virtually infinite
MTTFd	> 400 years
ELECTROMAGNETIC INTERFERENCE	EN 61000-4-3:1999 to 100V/m 80-1000MHz & 1.4-2.7GHz
SALT SPRAY	BS EN 60068-2-52:1996 test Kb severity 2

IMPORTANT INFORMATION

Whilst Curtiss-Wright Industrial Group - Penny & Giles has designed this sensor to meet a range of applications it is the responsibility of the customer to ensure it meets their specific requirement.

Penny & Giles Controls Ltd makes no warranty or representation in respect of product fitness or suitability for any particular design application, environment, or otherwise, except as may subsequently be agreed in contract for the sale and purchase of products. Customers should therefore satisfy themselves of the actual performance requirements and subsequently the product's suitability for any particular design application and the environment in which the product is to be used.

Continual research and development may require change to products and specification without prior notification.

All trademarks acknowledged.

NHR300DP | Rev A | 08/15