

Model T3 Precision-Pedestal Rotary Torque Transducer

- Capacities from 0.1 to 20K Nm (0.88 to 177K lb-in)
- Integral mounting base
- ± 5 VDC output
- Digital electronics
- Stainless steel shaft
- 12 to 28 VDC supply
- Contactless
- 10 kHz sample rate
- 16-bit resolution



OPTIONS

Speed & Angle Output - 360 Pulse TTL, 2-tracks 90° offset, available on capacities up to 1,000 Nm only
 Speed Output - 60 Pulse TTL, 1-track, available on capacities 2,000 Nm & above
 +10 V torque output
 RS485
 Keyed shafts - per DIN 6885.1

SPECIFICATIONS

ACCURACY – (MAX ERROR)	
Combined Error-% FS	± 0.1
Nonrepeatability-%	± 0.02
TEMPERATURE	
Effect on Zero- % RO/ $^{\circ}$ C	± 0.02
Effect on Output-%/ $^{\circ}$ C	± 0.01
Rated Range- $^{\circ}$ C	+5 to +45
Operating Range- $^{\circ}$ C	0 to +60
ELECTRICAL	
Output-VDC	± 5
Bandwidth, Hz	3 kHz-3dB
Calibration Signal-%RO	100
Supply Voltage-VDC	12 to 28
Supply Current-mA	60
Electrical Connection	12-pin
Resolution	16-bit
Sample Rate-kHz	10
MECHANICAL	
Safe Overload-% RO	200
Cyclic Load Rating-% RO	± 70 peak
Max Speed-rpm	Varies with capacity. See Table
Shaft	Stainless Steel
Housing	Aluminum

Model T3 Precision-Pedestal Rotary Torque Transducer – Capacities 0.1 to 1 Nm

DIMENSIONS

Nominal Torque				
Capacity (Nm)	0.1, 0.2		0.5, 1	
Equivalent (lb-in)	0.88, 1.77		4.43, 8.85	
	inch	mm	inch	mm
(1)	3.35	85	3.35	85
(2)	0.71	18	0.71	18
(3)	0.3148/ 0.3144	8g6	0.3148/ 0.3144	8g6
(4)	0.67	17	0.67	17

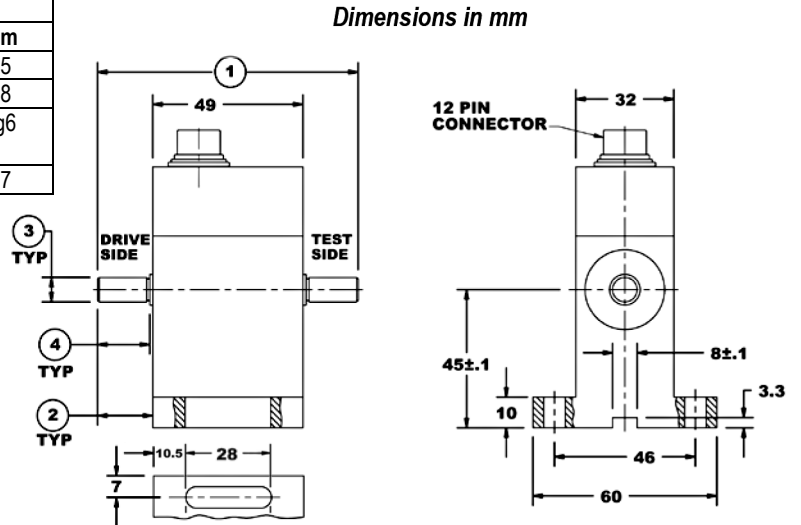

Model T3 Precision-Pedestal Rotary Torque Transducer – Capacities 2 to 100 Nm

DIMENSIONS

Nominal Torque								
Capacity (Nm)	2, 5		10, 15		20, 30		50, 100	
Equivalent (lb-in)	17.7, 44.3		88.5, 133		177, 265		443, 885	
	inch	mm	inch	mm	inch	mm	inch	mm
(1)	4.23	107.5	4.23	107.5	4.39	111.5	5.81	147.5
(2)	0.71	18	0.71	18	0.79	20	1.50	38
(3)	0.3148/ 0.3144	8g6	0.3935/ 0.3931	10g6	0.7087/ 0.7082	18 h6	0.7087/ 0.7082	18 h6
(4)	0.67	17	0.67	17	0.71	18	1.42	36

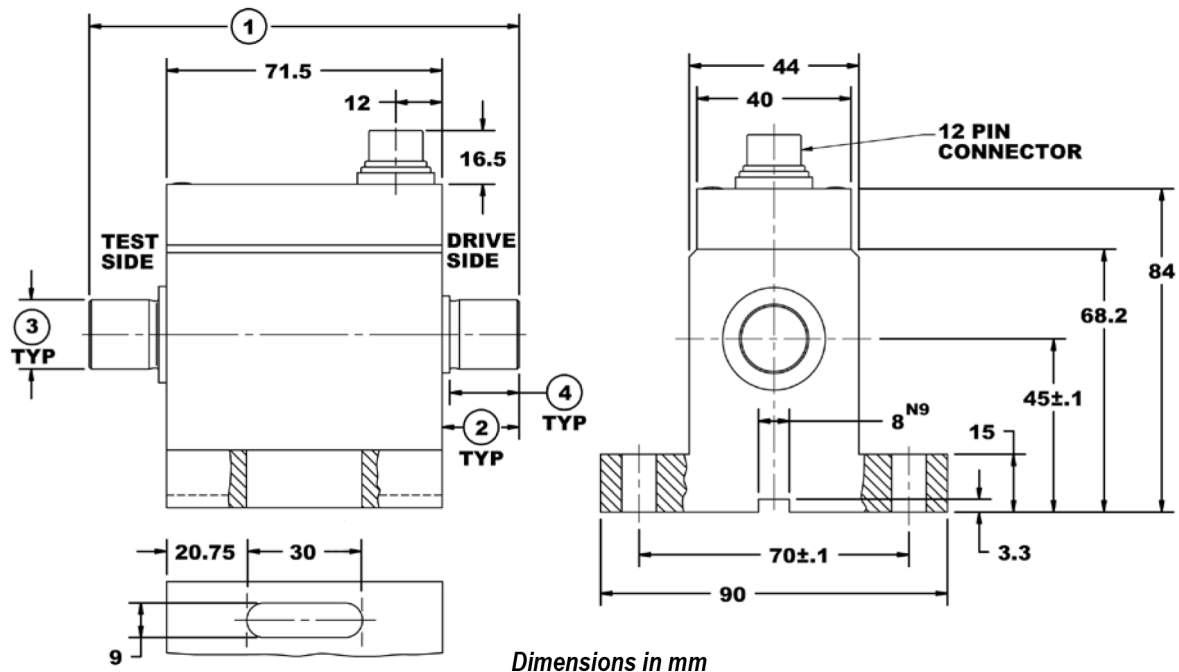

T3 Torque Precision-Pedestal Rotary Torque Transducer – Capacities 200 to 20,000 Nm

DIMENSIONS

Capacity (Nm)	Nominal Torque							
	200, 500		1K		2K, 5K		10K, 20K	
Equivalent (lb-in)	1.77K, 4.43K		8.85K		17K, 44.3K		85.5K, 177K	
	inch	mm	inch	mm	inch	mm	inch	mm
(1)	3.50	89	3.50	89	3.50	89	3.50	89
(2)	8.54	217	10.31	262	14.84	377	18.50	470
(3)	1.71	43.5	2.60	66	4.76	121	5.51	140
(4)	1.2595/ 1.2598	32 h6	1.9685/ 1.9675	50 h7	2.7559/ 2.7547	70 h7	4.3307/ 4.3293	110 h7
(5)	1.50	38	2.28	58	4.33	110	4.72	120
(6)	5.12	130	5.12	130	5.31	135	7.48	190
(7)	4.53	115	4.63	115	5.47	139	8.27	210
(8)	7.50	190.4	7.50	190.4	9.90	251.5	12.52	318
(9)	4.41	112	4.41	112	6.30	160	8.46	215
(10)	0.79	20	0.79	20	0.98	25	1.57	40
(11)	6.89	175	6.89	175	8.15	207	11.81	300
(12)	1.18	30	1.18	30	1.42	36	1.77	45
(13)	5.71	145	5.71	145	6.81	173	10.24	260

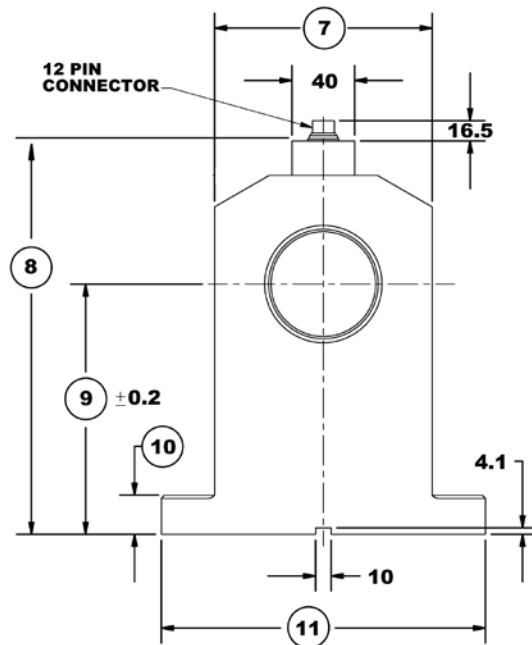
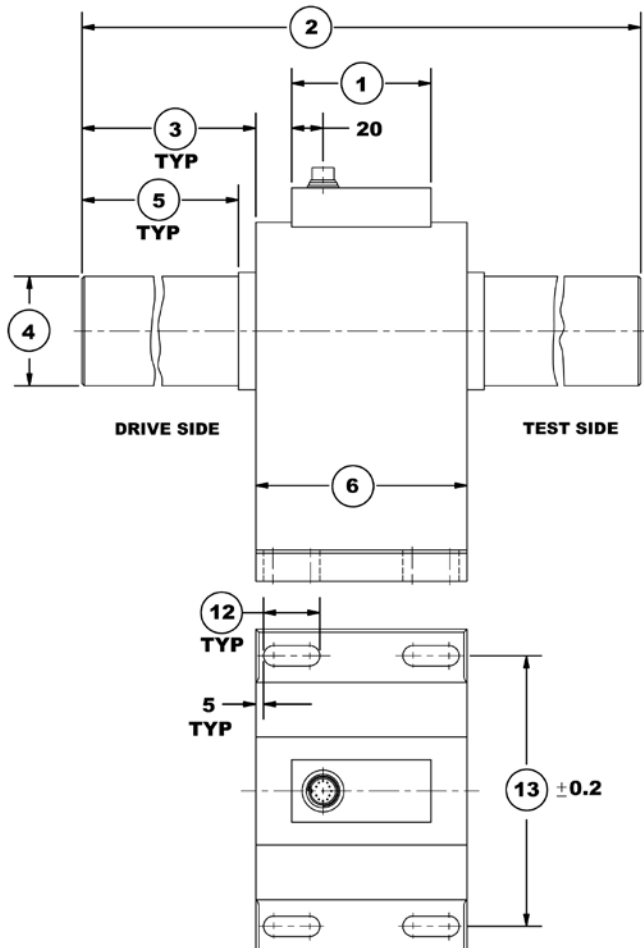

Dimensions in mm

T3 PRECISION ROTARY TORQUE TRANSDUCER PERFORMANCE PARAMETERS

CAPACITY (Nm)	MAX RPM	SPRINGRATE (Nm/rad)	MOMENT OF INERTIA , J (Kgxm ²)		MAX THRUST LOAD (N)
			Drive Side	Test Side	
0.1	15,000	1.8x10 ¹	1.9x10 ⁻⁶	2.8x10 ⁻⁷	15
0.2	15,000	1.8x10 ¹	1.9x10 ⁻⁶	2.8x10 ⁻⁷	15
0.5	15,000	1.2x10 ²	1.9x10 ⁻⁶	2.8x10 ⁻⁷	30
1	15,000	1.2x10 ²	2.0x10 ⁻⁶	2.8x10 ⁻⁷	40
2	12,000	4.4x10 ²	1.0x10 ⁻⁵	8.1x10 ⁻⁶	50
5	12,000	4.4x10 ²	1.0x10 ⁻⁵	8.1x10 ⁻⁶	50
10	12,000	1.7x10 ³	1.0x10 ⁻⁵	8.2x10 ⁻⁶	50
15	12,000	1.7x10 ³	1.0x10 ⁻⁵	8.2x10 ⁻⁶	100
20	12,000	4.5x10 ³	1.2x10 ⁻⁵	9.9x10 ⁻⁶	300
30	12,000	4.5x10 ³	1.2x10 ⁻⁵	9.9x10 ⁻⁶	1,000
50	12,000	6.1x10 ³	1.3x10 ⁻⁵	1.1x10 ⁻⁵	1,600
100	12,000	9.7x10 ³	1.4x10 ⁻⁵	1.2x10 ⁻⁵	2,600
200	7,000	9.2x10 ⁴	1.3x10 ⁻³	8.0x10 ⁻⁴	3,200
500	7,000	9.2x10 ⁴	1.3x10 ⁻³	8.0x10 ⁻⁴	7,500
1,000	7,000	3.1x10 ⁵	1.6x10 ⁻³	1.1x10 ⁻³	10,000
2,000	5,500	7.2x10 ⁵	5.3x10 ⁻³	4.3x10 ⁻³	18,000
5,000	5,500	8.0x10 ⁵	5.4x10 ⁻³	4.3x10 ⁻³	32,000
10,000	3,500	3.1x10 ⁶	4.0x10 ⁻²	3.7x10 ⁻²	125,000
20,000	3,500	3.7x10 ⁶	4.0x10 ⁻²	3.8x10 ⁻²	200,000

ELECTRICAL CONNECTION

Pin	12-Pin		12-Pin RS485 Option	
	Function	Description	Function	Description
A	NC	-	NC	-
B	Option Angle B	TTL	Option Angle B	TTL
C	Signal (+)	±5 VDC	NC	-
D	Signal (GND)	0 VDC	NC	-
E	Supply (GND)	0 VDC, TTL	Supply (GND)	0 VDC
F	Supply (+)	12-28 V	Supply (+)	12-28 VDC
G	Option Angle A	TTL	Option Angle A	TTL
H	NC	-	NC	-
J	NC	-	RS485 Option	RS485 (B)
K	Cal. Control	L < 2.0 V / H > 3.5 V	NC	-
L	NC	-	RS485 Option	RS485 (A)
M	Housing		Housing	