

Model T5 General Purpose-Pedestal Rotary Torque Transducer

- Capacities from 0.1 Nm to 1K Nm (0.85 to 8.85K lb-in)
- Integral mounting base
- ± 5 VDC output
- Digital electronics
- Stainless steel shaft
- 12 to 28 VDC supply
- Contactless
- 10 kHz sample rate
- 12-bit resolution



OPTIONS

Speed & Angle Measurement - 360 Pulse TTL, 2-tracks 90° offset, available on capacities up to 1,000 Nm only
 Speed Output - 60 Pulse TTL, 1-track, available on capacities 2,000 Nm & above
 +10 V torque output
 RS485
 Keyed shafts - per Din 6885.1

SPECIFICATIONS

ACCURACY – (MAX ERROR)	
Combined Error-% FS	± 0.2
Nonrepeatability-%	± 0.04
TEMPERATURE	
Effect on Zero- % RO/ $^{\circ}$ C	± 0.03
Effect on Output-%/ $^{\circ}$ C	± 0.015
Rated Range- $^{\circ}$ C	+5 to +45
Operating Range- $^{\circ}$ C	0 to +60
ELECTRICAL	
Output-VDC	± 5
Bandwidth, Hz	3 kHz-3dB
Calibration Signal-%RO	100
Supply Voltage-VDC	12 to 28
Supply Current-mA	60
Electrical Connection	12-pin
Resolution	12-bit
Sample Rate-kHz	10
MECHANICAL	
Safe Overload-% RO	200
Cycle Load Rating-% RO	± 70 peak
Max Speed-rpm	Varies with capacity. See Table
Shaft	Stainless Steel
Housing	Aluminum

Model T5 General Purpose-Pedestal Rotary Torque Transducer – Capacities 0.1 to 1 Nm

DIMENSIONS

Nominal Torque				
Capacity (Nm)	0.1, 0.2		0.5, 1	
Equivalent (lb-in)	0.85, 1.77		4.43, 8.85	
	inch	mm	inch	mm
(1)	3.35	85	3.35	85
(2)	0.71	18	3.86	98
(3)	0.3148/ 0.3144	8g6	0.3148/ 0.3144	8g6
(4)	0.67	17	0.67	17

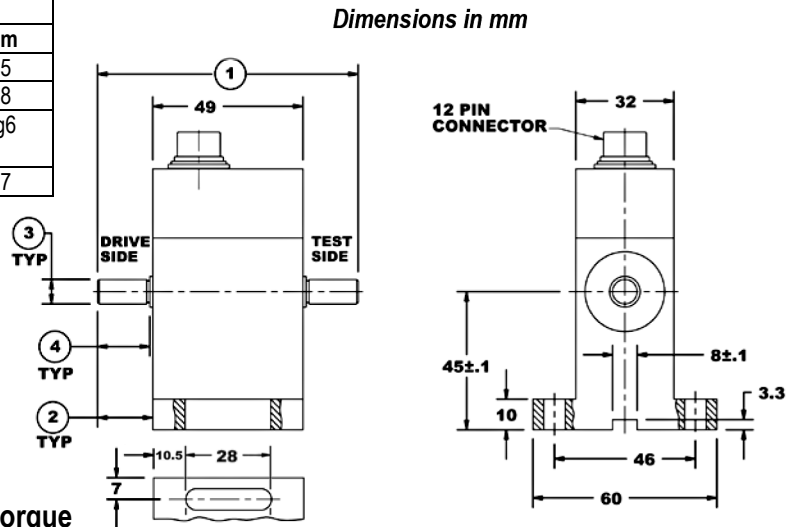

Model T5 General Purpose-Pedestal Rotary Torque Transducer – Capacities 2 to 100 Nm

DIMENSIONS

Nominal Torque								
Capacity (Nm)	2, 5		10, 15		20, 30		50, 100	
Equivalent (lb-in)	17.7, 44.3		88.5, 133		177, 265		443, 885	
	inch	mm	inch	mm	inch	mm	inch	mm
(1)	4.23	107.5	4.23	107.5	4.39	111.5	5.81	147.5
(2)	0.71	18	0.71	18	0.79	20	1.50	38
(3)	0.3148/ 0.3144	8g6	0.3935/ 0.3931	10g6	0.7087/ 0.7082	18 h6	0.7087/ 0.7082	18 h6
(4)	0.67	17	0.67	17	0.71	18	1.42	36

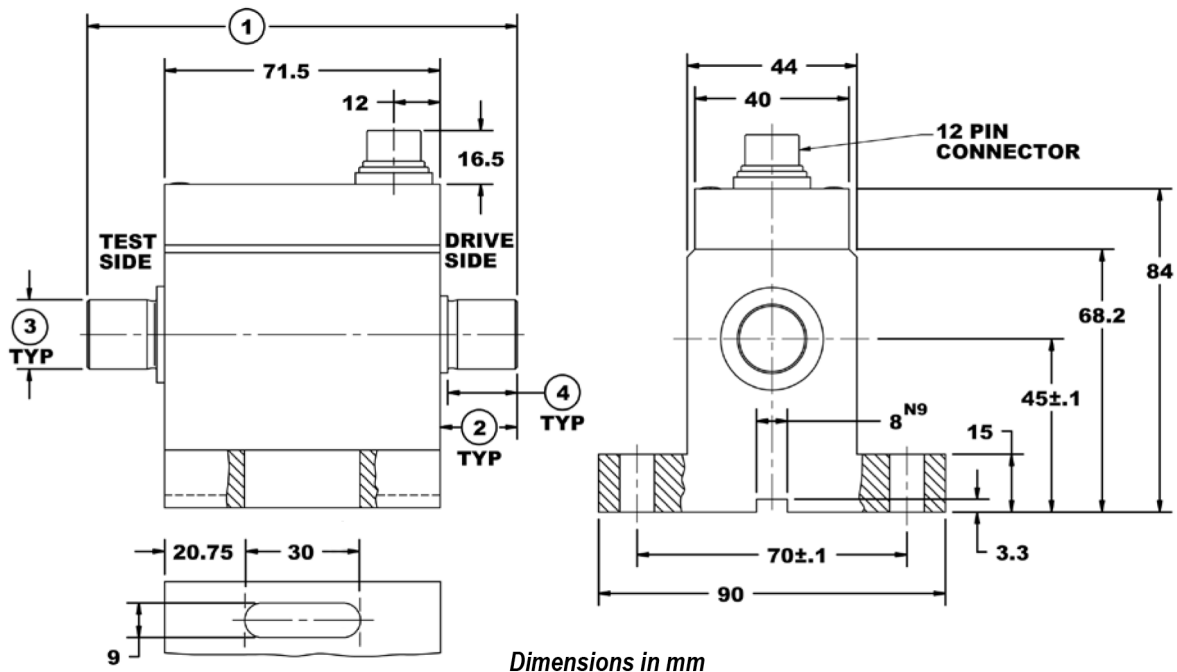

Model T5 General Purpose-Pedestal Rotary Torque Transducer – Capacities 200 to 1,000 Nm

DIMENSIONS

Capacity (Nm)	200, 500		1K	
Equivalent (lb-in)	1.77K, 4.43K		8.85K	
	inch	mm	inch	mm
(1)	3.50	89	3.50	89
(2)	8.54	217	10.31	262
(3)	1.71	43.5	2.60	66
(4)	1.2595/ 1.2598	32 h6	1.9685/ 1.9675	50 h7
(5)	1.50	38	2.28	58
(6)	5.12	130	5.12	130
(7)	4.53	115	4.63	115
(8)	7.50	190.4	7.50	190.4
(9)	4.41	112	4.41	112
(10)	0.79	20	0.79	20
(11)	6.89	175	6.89	175
(12)	1.18	30	1.18	30
(13)	5.71	145	5.71	145

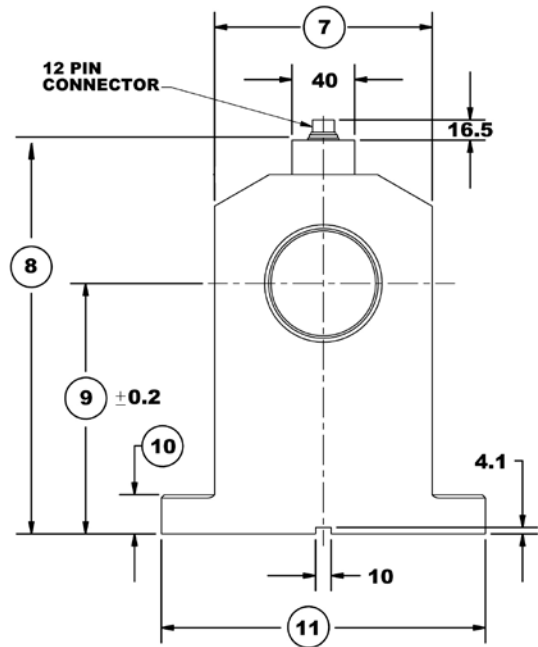
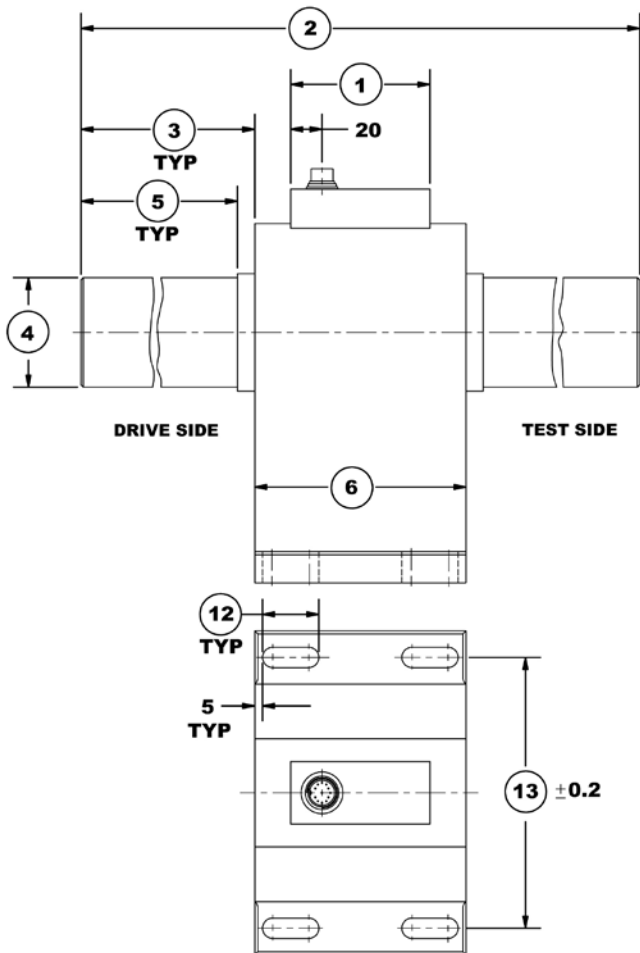

Dimensions in mm

T5 PRECISION ROTARY TORQUE TRANSDUCER PERFORMANCE PARAMETERS

CAPACITY (Nm)	MAX RPM	SPRINGRATE (Nm/rad)	MOMENT OF INERTIA , J (Kgxm ²)		MAX THRUST LOAD (N)
			Drive Side	Test Side	
0.1	15,000	1.8x10 ¹	1.9x10 ⁻⁶	2.8x10 ⁻⁷	15
0.2	15,000	1.8x10 ¹	1.9x10 ⁻⁶	2.8x10 ⁻⁷	15
0.5	15,000	1.2x10 ²	1.9x10 ⁻⁶	2.8x10 ⁻⁷	30
1	15,000	1.2x10 ²	2.0x10 ⁻⁶	2.8x10 ⁻⁷	40
2	12,000	4.4x10 ²	1.0x10 ⁻⁵	8.1x10 ⁻⁶	50
5	12,000	4.4x10 ²	1.0x10 ⁻⁵	8.1x10 ⁻⁶	50
10	12,000	1.7x10 ³	1.0x10 ⁻⁵	8.2x10 ⁻⁶	50
15	12,000	1.7x10 ³	1.0x10 ⁻⁵	8.2x10 ⁻⁶	100
20	12,000	4.5x10 ³	1.2x10 ⁻⁵	9.9x10 ⁻⁶	300
30	12,000	4.5x10 ³	1.2x10 ⁻⁵	9.9x10 ⁻⁶	1,000
50	12,000	6.1x10 ³	1.3x10 ⁻⁵	1.1x10 ⁻⁵	1,600
100	12,000	9.7x10 ³	1.4x10 ⁻⁵	1.2x10 ⁻⁵	2,600
200	7,000	9.2x10 ⁴	1.3x10 ⁻³	8.0x10 ⁻⁴	3,200
500	7,000	9.2x10 ⁴	1.3x10 ⁻³	8.0x10 ⁻⁴	7,500
1,000	7,000	3.1x10 ⁵	1.6x10 ⁻³	1.1x10 ⁻³	10,000

ELECTRICAL CONNECTION

Pin	12-Pin		12-Pin RS485 Option	
	Function	Description	Function	Description
A	NC	-	NC	-
B	Option Angle B	TTL	Option Angle B	TTL
C	Signal (+)	±5 VDC	NC	-
D	Signal (GND)	0 VDC	NC	-
E	Supply (GND)	0 VDC	Supply (GND)	0 VDC
F	Supply (+)	12-28 VDC	Supply (+)	12-28 VDC
G	Option Angle A	TTL	Option Angle A	TTL
H	NC	-	NC	-
J	NC	-	RS485 Option	RS485 (B)
K	Cal. Control	L < 2.0 / H > 3.5V	NC	-
L	NC	-	RS485 Option	RS485 (A)
M	Housing		Housing	