



XMO2pro

Oxygen Analyzer

Applications

- Inerting/blanketing liquid storage tanks
- Reactor feed gases
- Centrifuge gases
- Catalyst regeneration
- Solvent recovery
- Landfill/Biogas processing
- Sewage wastewater digester gas
- Oxygen purity
- Reaction optimization

Benefits

- Accurate measurements from 0.01% to 100% O₂ in gases
- Compact design for cost-effective integration into the process
- Explosion-proof and flameproof certified with weatherproof protection allows sensor to be remotely mounted at the measurement point
- Unique, temperature-controlled dual-chamber cell design that is resistant to contamination and flow fluctuations
- Compact, rugged sensor design with no moving parts provides long term reliability and trouble-free operation
- High-contrast display, large magnetic buttons for easy control under different environmental conditions
- Intuitive user interface enables easy and flexible use
- The MODBUS communication port provides extended information with configurable options
- Minimal and on-site/user-controllable maintenance

Thanks to the perfectly matched interaction between the paramagnetic oxygen property and temperature, the Safety Integrity Level (SIL) certified XMO2pro is contamination resistant, requires minimal maintenance and needs no consumables. This makes it the ultimate choice for highly accurate oxygen measurements for widespread use in harsh environment industrial and oil & gas applications.

Advanced Oxygen Analyzer

Designed for stability and longevity in hazardous area locations, the XMO2pro provides high accuracy percent-level brings the user:

- Innovative sensor design for durable and highly accurate measurements
- Intuitive operating interface allows for easy adoption and use
- Data transfer over the MODBUS digital communication port
- Minimal maintenance and high level of reliability with SIL 2 by design
- Compact design for cost-effective Integration into the process

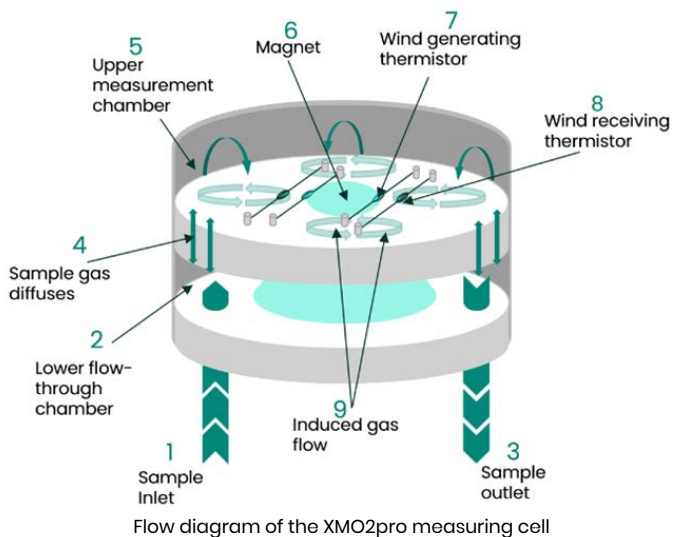

Sample gas continually flows through the lower flow-through chamber (1)(2)(3). This chamber acts as a pass-through and protects the sensor from contamination. A portion of the sample gas diffuses (4) into the upper chamber (5). The oxygen molecules are drawn into the center by the magnet (6) and leave across the heated matched thermistor pairs (7)(8) creating a “magnetic wind” (9). These thermistor pairs form part of a Wheatstone bridge, which generates a signal proportional to the oxygen concentration in the sample gas.

Top performance and ease of use

The compact, weatherproof, explosion-proof and flameproof XMO2pro is specifically designed to be field installed at the process measurement point, thus minimizing sample-conditioning requirements while ensuring the best sample and the fastest possible response. The XMO2pro requires no consumables, has no moving parts, is insensitive to vibration and therefore has excellent long-term reliability.

Choice of enclosures and ranges

The XMO2pro requires 24 VDC power and provides a 4 to 20 mA output signal with fully programmable zero and span settings. The output is proportional to oxygen concentration and internally compensated for background gas and/or atmospheric pressure variations. The additional 4–20 mA output can be configured by the operator to provide an alternative concentration range using the calibration of the first 4–20mA output. The weatherproof and explosion-proof options are available in a wide variety of measurement ranges.

Sample System

Sample systems deliver a clean, representative sample to the XMO2pro at optimal temperatures, pressures and flow rates. Panametrics offers sample systems for a wide variety of applications.

For assistance in designing your own sample system, please consult our application engineering team.



Automatic background gas compensation

An onboard microprocessor gives the XMO2pro the computing power to provide advanced online signal conditioning and MODBUS digital communications. Integrated signal-processing algorithms provide improved linearity and accuracy, and automatic compensation for background gas variations and/or atmospheric pressure effects. A fast response software routine provides typical response time of less than 15 seconds.

Technical Specifications



- 1 Configuration and certification information
- 2 Mounting holes
- 3 Cable entries
- 4 Removable top cover
- 5 Removable front cover
- 6 Multi-parameter display
- 7 Magnetic keypad
- 8 Flame arrestors (gas inlet/outlet) and breather

Performance

Accuracy:

- $\pm 1\%$ of span
- $\pm 2\%$ of span for 0 to 1% range

Linearity: $\pm 0.5\%$ of span

Repeatability: $\pm 0.2\%$ of span

Zero stability:

- $\pm 1\%$ of span per month ($\pm 2\%$ for 0 to 1% range)

Span stability:

- $\pm 0.4\%$ of span per month ($\pm 0.8\%$ for 0 to 1% range)

Measurement Ranges:

- 0% to 1%
- 0% to 2%
- 0% to 5%
- 0% to 10%
- 0% to 21%
- 0% to 25%
- 0% to 50%*
- 0% to 100%*
- 80% to 100%*
- 90% to 100%*

Pressure effect:

- $\pm 0.2\%$ of reading per mm Hg (without atmospheric pressure compensation)
- Option available for atmospheric pressure compensation

Required sample flow rate:

- Nominal: 500 cc/min (1.0 SCFH)
- Range: 50–1000 cc/min (0.1–2.0 SCFH)
- Max: 1250 cc/min (2.7 SCFH)**

Sample flow rate effect:

- Less than 1% of span for flow range of 50 to 1000 cc/min (0.1 to 2.0 SCFH)

Response time, 90% step change:

- Standard: 70 seconds
- EN50104: 45 seconds
- Fast-Response Option: 15 seconds

*Pressure compensation required

**Maximum permitted per Annex G of IEC60079-1

Functional and Physical

Warm-up time: 30 minutes

Functional Safety: IEC61508 SIL 2 (optional)

Analog output:

Two 4 to 20 mA isolated, 550 Ω maximum load, field-programmable

Digital output: Modbus RS232/RS485

Power: 24 VDC ± 4 VDC, 2.5 A

Ambient temperature range (Sample conditions):

- -20 to 40°C (-4 to 104°F), standard cell operating temperature
- -5 to 55°C (23 to 131°F), optional cell operating temperature

Operating pressure: Close to atmospheric

- Max 2 barg (29 psig)

Wetted sensor materials:

- Standard: 316 stainless steel, glass and Viton® O-rings
- Optional: Hastelloy® C276 and Chemraz® O-rings
- Optional: 316 Stainless steel, glass and Chemraz® O-Rings

Dimensions:

- Wp. (H x D x W): 228 x 178 x 142mm (9 x 7 x 6in)
- Ex-proof (H x D x W): 252 x 178 x 142mm (10 x 7 x 6in)

Weight:

- Aluminum version: 4.5 kg / 9.9 lb
- Stainless Steel version: 11.0 kg / 24.2 lb

Environmental:

- IP66, Type 4X

IECEx compliance

- Ex db IIC T6 Gb, Ex tb IIIC T78°C Db IP66
- $-20^\circ\text{C} < T_{\text{amb}} < +55^\circ\text{C}$

European Union Compliance

- EMC Directive 2014/30/EU
- ATEX 2014/34/EU: II 2 GD Ex db IIC T6 Gb, Ex tb IIIC T78°C Db IP66
- $-20^\circ\text{C} < T_{\text{amb}} < +55^\circ\text{C}$

NEC/CEC

- Cl I, II, III Div 1/Div 2. Groups ABCDEFG, T6
- $-20^\circ\text{C} < T_{\text{amb}} < +55^\circ\text{C}$

Aluminum Version

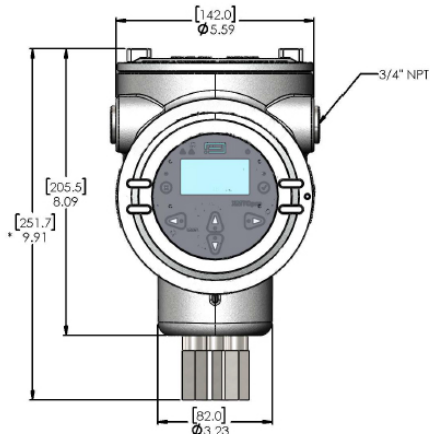
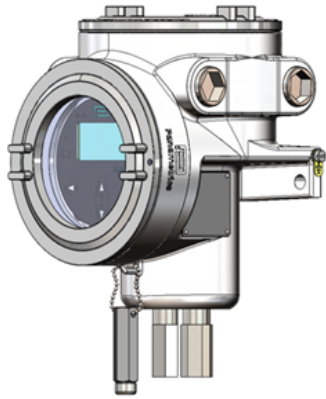

*8.96 [227.6] WEATHERPROOF VERSION

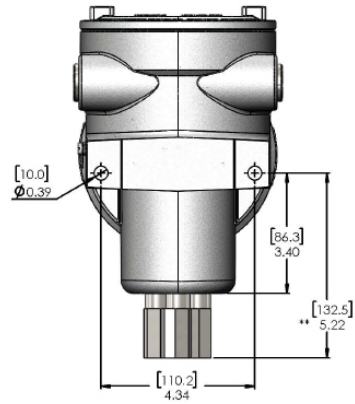

**4.27 [108.5] WEATHERPROOF VERSION

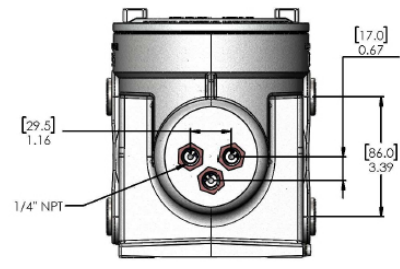
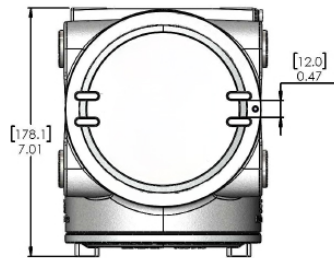

[mm]
in

Stainless Steel Version

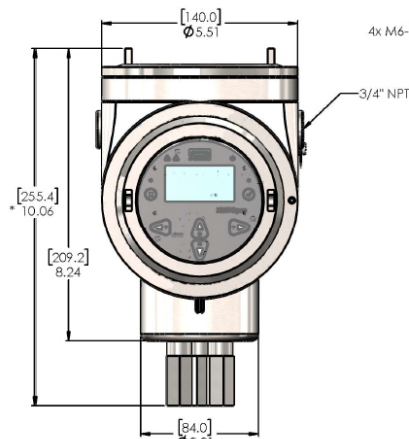
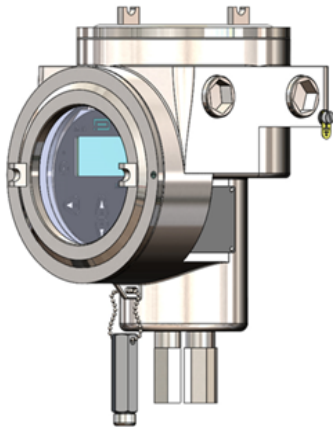

*9.11 [231.4] WEATHERPROOF VERSION

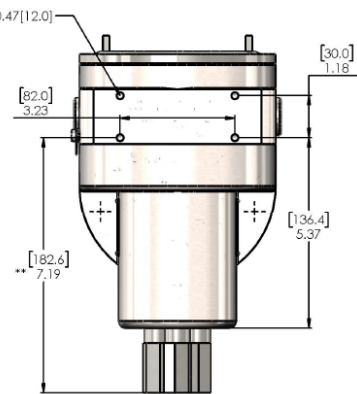

**6.24 [158.5] WEATHERPROOF VERSION

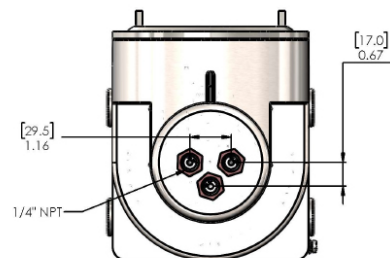
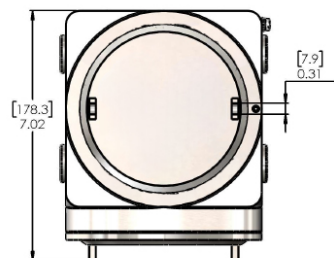

[mm]
in

Ordering information

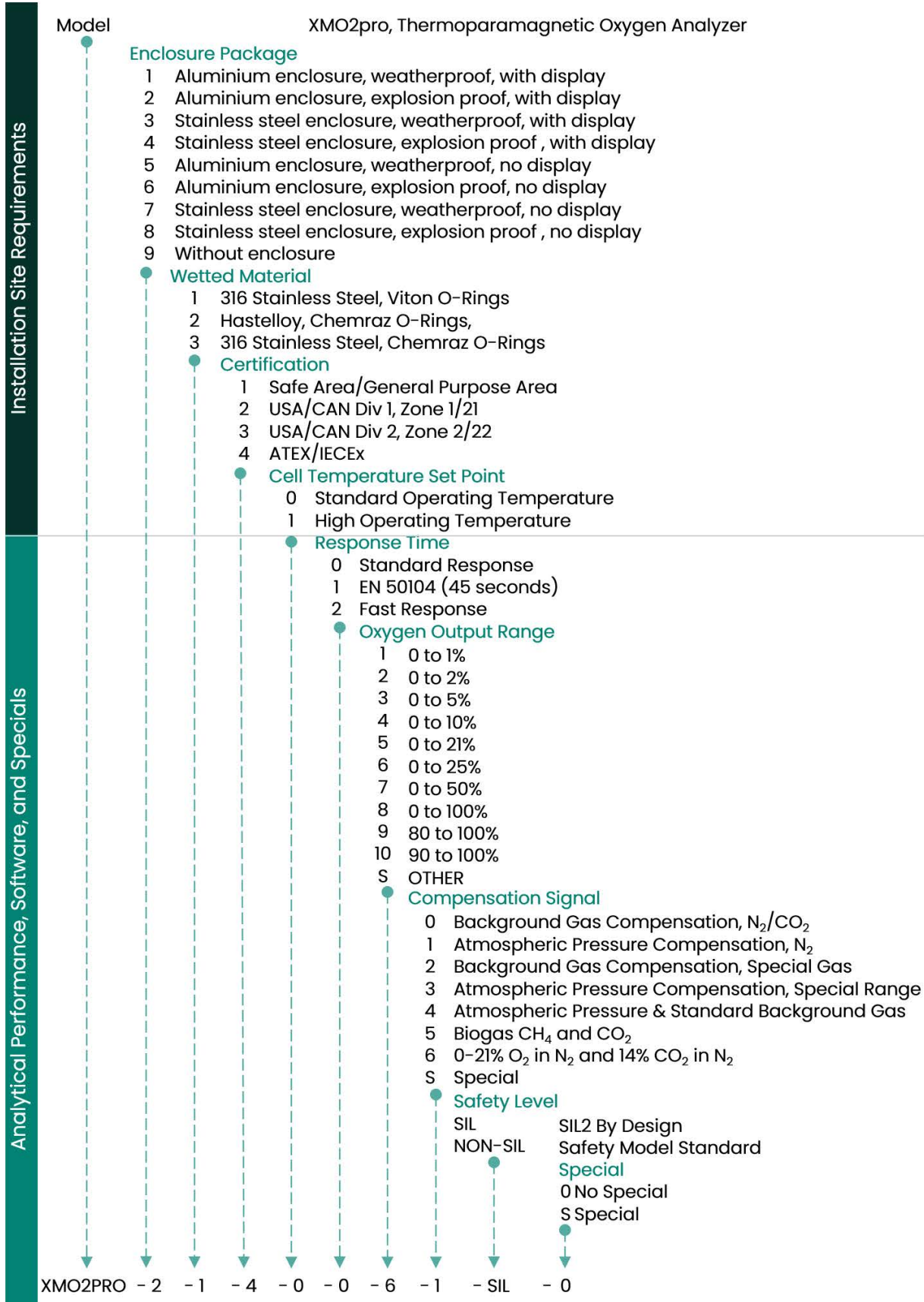

Panametrix, a Baker Hughes business, provides solutions in the toughest applications and environments for moisture, oxygen, liquid and gas flow measurement.

Experts in flare management, Panametrix technology also reduces flare emissions and optimizes performance.

With a reach that extends across the globe, Panametrix' critical measurement solutions and flare emissions management are enabling customers to drive efficiency and achieve carbon reduction targets across critical industries including: Oil & Gas; Energy; Healthcare; Water and Wastewater; Chemical Processing; Food & Beverage and many others.

Join the conversation and follow us on LinkedIn
[linkedin.com/company/panametrixcompany](https://www.linkedin.com/company/panametrixcompany)